

SPECIFICATION CONTROL DRAWING

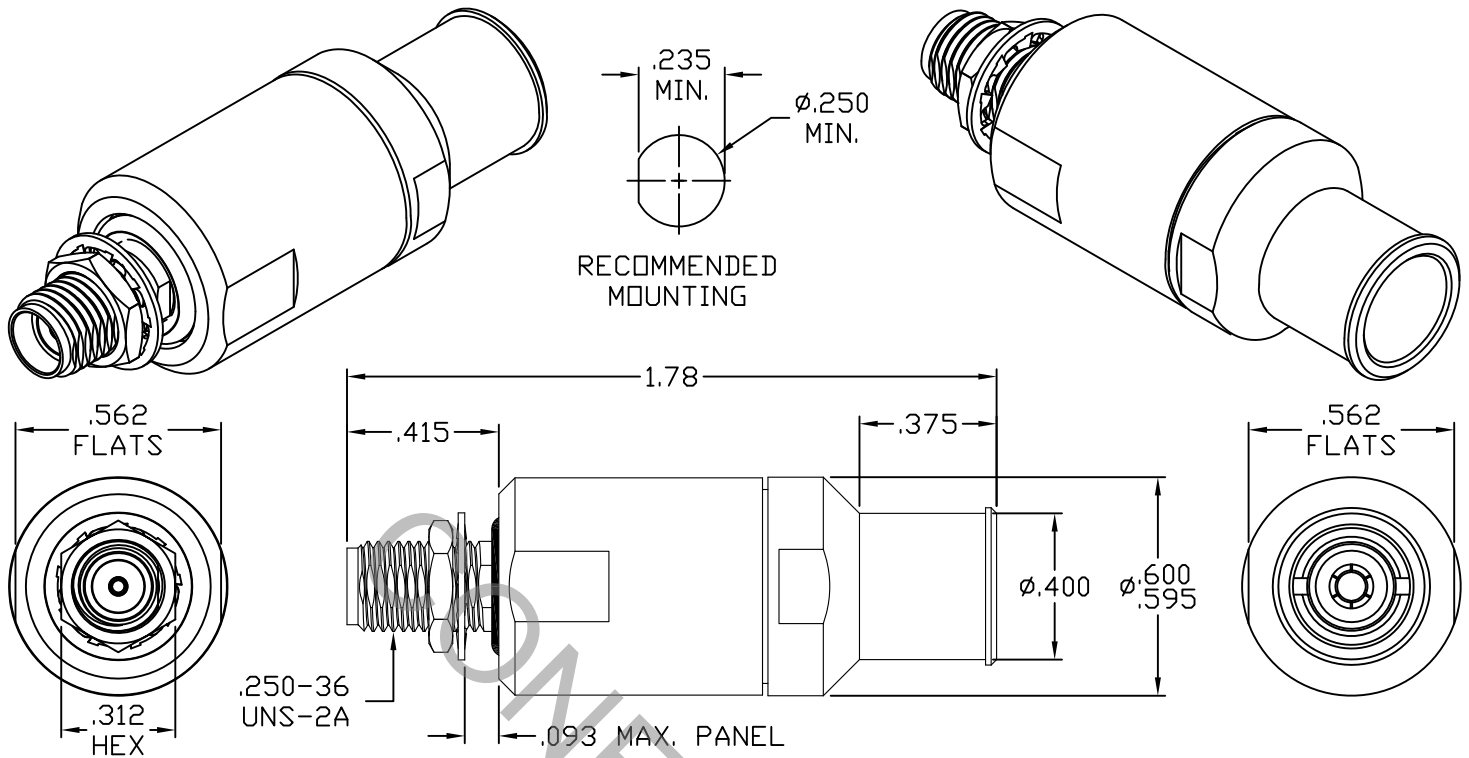

1. MATING INTERFACE DIMENSIONS Per MIL-STD-348 Fig. 310.2 (SMA JACK).

2. ELECTRICAL

FREQUENCY RANGE GHz	_____	DC TO 18.0 GHz
VSWR (MAX) *	_____	1.05 + .005 x FGHz
INSERTION LOSS (dB MAX) *	_____	.04 dB x √FGHz
NOMINAL IMPEDANCE (OHMS)	_____	50
VOLTAGE RATING (MAX. VRMS)	_____	333
RF LEAKAGE (MIN. dB DOWN)	_____	-100 dB - FGHz
TEMPERATURE RATING (DEGREES CENTIGRADE)	_____	-65°c TO + 165°c
DIELECTRIC WITHSTANDING VOLTAGE (MAX. VRMS)	_____	1,000
INSULATION RESISTANCE (MIN. MEGOHMS)	_____	5,000
CONTACT RESISTANCE		
• CENTER CONTACT (MAX. MILLIOHMS)	_____	6.0
• OUTER CONTACT (MAX. MILLIOHMS)	_____	2.0

* TERMINATED IN A 50 OHM LOAD

RoHS
COMPLIANT

This Document contains proprietary and confidential information.

REV.	DCN NO.	DATE	APP.	DIMENSIONS ARE IN INCHES TOLERANCES			CABLE INCORPORATED HAVERHILL, MA 01835
				DECIMALS	FRACTIONAL	ANGULAR	
AA	13-1378	3/15/13	DC	.X ± .030 .XX ± .010 .XXX ± .005	± 1/64	X ° ± 1° 0' X ° X' ± 15'	
AB	13-2080	8/2/13	DC				
				DRAWN RMS	DATE	3/15/13	TITLE SMA JACK, BULKHEAD, SOLDER CLAMP, PLUG-IN, CTC, DF118 LOW LOSS
				APPROVED DC	DATE	3/15/13	
				CODE IDENT. 6DZL5	SHEET 1 OF 2	DWG. NO. 9910-118H-6240	

SPECIFICATION CONTROL DRAWING

3. MECHANICAL

CAPTIVATION-CENTER CONTACT
 MAX. AXIAL FORCE _____ 6.0 LBS.
 MAX. RADIAL TORQUE _____ N/A
 CENTER CONTACT AXIAL FORCES
 ● INSERTION (MAX. OUNCES) _____ INTERFACE 32.0
 ● WITHDRAWAL (MIN. OUNCES) _____ INTERFACE 2.0
 CONNECTOR ENGAGEMENT/DISENGAGEMENT (MAX. LBS.) _____ 2.0
 CONNECTOR DURABILITY (MIN. CYCLES) _____ 500
 RECOMMENDED MATING TORQUE _____ 7 - 10 IN. LBS.
 RECOMMENDED MOUNTING TORQUE _____ 18 - 22 IN. LBS.

4. ENVIRONMENTAL

THERMAL SHOCK _____ MIL-STD-202, METHOD 107, COND. B (-65° c TO +165° c)
 SHOCK _____ MIL-STD-202, METHOD 213, COND. I (100 G's)
 VIBRATION _____ MIL-STD-202, METHOD 204, COND. D (20 G's)
 MOISTURE RESISTANCE _____ MIL-STD-202, METHOD 106, LESS STEP 7b
 CORROSION _____ MIL-STD-202, METHOD 101, COND. B (48 HOURS)
 BAROMETRIC PRESSURE (ALTITUDE) _____ MIL-STD-202, METHOD 105, COND. C (70,000 FT.) (190 VRMS)

5. MATERIAL

BODY, PRESS SLEEVE, HEX NUT & CLAMP NUT _____ STAINLESS STEEL PER ASTM-A-582, TYPE 303, COND. A
 LOCKWASHER _____ 400 SERIES STAINLESS STEEL
 CONTACTS _____ BERYLLIUM COPPER PER ASTM-B-196/B, 196M-03, COPPER ALLOY No. UNS-C17300, TEMPER TD04.
 INTERFACE INSULATOR _____ TEFLON PER ASTM-D-1710-02, TYPE 1, GRADE 1, CLASS B.
 REAR INSULATOR _____ CROSS LINKED POLYETHYLENE (400° F).
 SOLDER SLEEVE _____ BRASS PER ASTM-B-16, TEMPER H02, ALLOY C36000.
 O-RINGS _____ SILICONE RUBBER PER ZZ-R-765E, CLASS 1 OR ASM-3304.

6. FINISH

BODY, PRESS SLEEVE, HEX NUT, LOCKWASHER & CLAMP NUT _____ PASSIVATE PER AMS 2700, TYPE 2, CLASS 4.
 SOLDER SLEEVE _____ GOLD PER ASTM-B-488, TYPE I, CODE C, CLASS 1.27
 (.000050 MIN. THK.) OVER NICKEL PER SAE AMS QQ-N-290, CLASS 1
 (.000150 MIN. THK.) OVER COPPER PER AMS 2418 (.000010 MIN. THK.)
 CONTACTS _____ GOLD PER ASTM-B-488, TYPE I, CODE C, CLASS 0.75
 (.000030 MIN. THK.) OVER NICKEL PER SAE AMS QQ-N-290, CLASS 1
 (.000050 MIN. THK.) OVER COPPER PER AMS 2418 (.000010 MIN. THK.)
 INSULATORS & O-RINGS _____ N/A