

SPECIFICATION CONTROL DRAWING

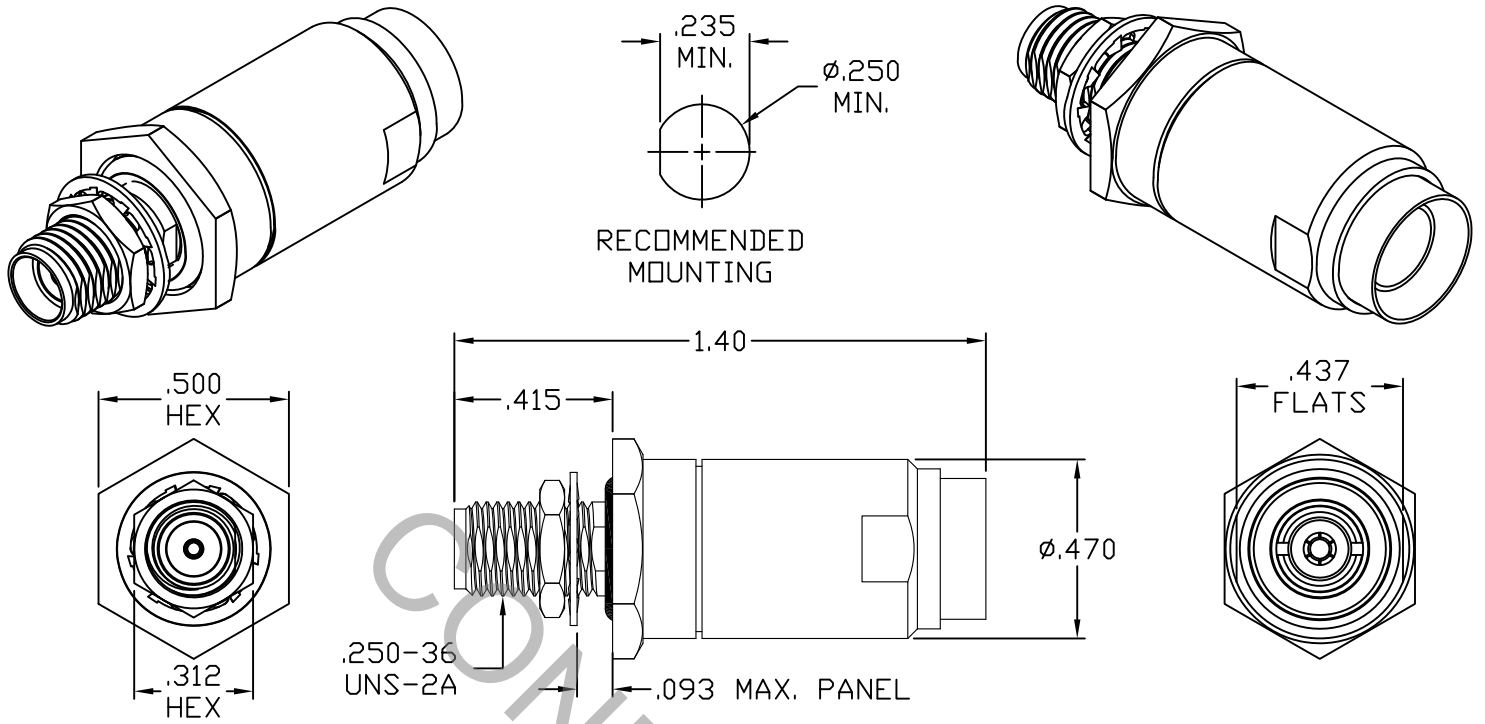

SOLD ON DYNAWAVE CABLE ASSEMBLIES ONLY

1. MATING INTERFACE DIMENSIONS Per MIL-STD-348 Fig. 310.2 (SMA JACK).
2. ELECTRICAL

FREQUENCY RANGE GHz _____	DC TO 26.5 GHz
VSWR (MAX.) * _____	1.05 + .006 x FGHz
INSERTION LOSS (dB MAX.) * _____	.05 dB x $\sqrt{\text{FGHz}}$
NOMINAL IMPEDANCE (OHMS) _____	50
VOLTAGE RATING (MAX. VRMS) _____	400
RF LEAKAGE (MIN. dB DOWN) _____	-100 dB - FGHz
TEMPERATURE RATING (DEGREES CENTIGRADE) _____	-65°C TO + 148°C
DIELECTRIC WITHSTANDING VOLTAGE (MAX. VRMS) _____	1,250
INSULATION RESISTANCE (MIN. MEGOHMS) _____	5,000
CONTACT RESISTANCE	
• CENTER CONTACT (MAX. MILLIOHMS) _____	6.0
• OUTER CONTACT (MAX. MILLIOHMS) _____	2.0

* TERMINATED IN A 50 OHM LOAD

RoHS
COMPLIANT

This Document contains proprietary and confidential information.

REV.	DCN NO.	DATE	APP.	DIMENSIONS ARE IN INCHES TOLERANCES			 Haverhill, MA 01835
				DECIMALS	FRACTIONAL	ANGULAR	
AA	13-1553	4/16/13	DC	.X ± .030		X ° ± 1° 0'	
AB	13-2079	8/2/13	DC	.XX ± .010	± 1/64	X ° X' ± 15'	
				DRAWN	RMS	DATE	TITLE SMA JACK, BULKHEAD SOLDER CLAMP, PLUG-IN CTC, DF126 LIGHT ARMOR
				APPROVED	DC	DATE	
				CODE IDENT.			DWG. NO. 9910-126R-6240
				6DZL5		SHEET 1 OF 2	

SPECIFICATION CONTROL DRAWING

3. MECHANICAL

CAPTIVATION-CENTER CONTACT
MAX AXIAL FORCE _____ 6.0 LBS.
MAX RADIAL TORQUE _____ N/A
CENTER CONTACT AXIAL FORCES
● INSERTION (MAX OUNCES) _____ 40.0
● WITHDRAWAL (MIN. OUNCES) _____ 2.0
CONNECTOR ENGAGEMENT/DISENGAGEMENT (MAX. LBS.) _____ 2.0
CONNECTOR DURABILITY (MIN. CYCLES) _____ 500
RECOMMENDED MATING TORQUE _____ 7 - 10 IN. LBS.
RECOMMENDED MOUNTING TORQUE _____ 18 - 22 IN. LBS.

4. ENVIRONMENTAL

TEMPERATURE CYCLING _____ MIL-STD-202, METHOD 107, COND. C (-65° c TO + 148° c)
SHOCK _____ MIL-STD-202, METHOD 213, COND. I (100 G's)
VIBRATION _____ MIL-STD-202, METHOD 204, COND. D (20 G's)
MOISTURE RESISTANCE _____ MIL-STD-202, METHOD 106, LESS STEP 7b
CORROSION _____ MIL-STD-202, METHOD 101, COND. B (48 HOURS)
BAROMETRIC PRESSURE (ALTITUDE) _____ MIL-STD-202, METHOD 105, COND. C (70,000 FT.) (300 VRMS)

5. MATERIAL

BODY, HEX NUT, CLAMP NUT, BUSHINGS & _____ STAINLESS STEEL PER ASTM-A-582, TYPE 303, COND. A
PRESS SLEEVE
LOCKWASHER _____ 400 SERIES STAINLESS STEEL
CONTACTS _____ BERYLLIUM COPPER PER ASTM-B-196/B, 196M-03, COPPER
ALLOY No. UNS-C17300, TEMPER TD04.
FRONT INSULATOR _____ TEFLON PER ASTM D-1710-02, TYPE 1, GRADE 1, CLASS B.
REAR INSULATOR _____ CROSS LINKED POLYETHYLENE (200° C)
O-RINGS _____ SILICONE RUBBER PER ZZ-R-765.
SOLDER SLEEVE _____ BRASS PER ASTM-B-16, TEMPER H02, ALLOY C36000.

6. FINISH

BODY, HEX NUT, CLAMP NUT, LOCKWASHER _____ PASSIVATE PER AMS 2700, TYPE 2, CLASS 4.
BUSHINGS & PRESS SLEEVE
SOLDER SLEEVE _____ GOLD PER ASTM-B-488, TYPE I, CODE C, CLASS 1.27
(.000050 MIN. THK.) OVER NICKEL PER SAE AMS QQ-N-290 CLASS 1
(.000150 MIN. THK.) OVER COPPER PER AMS 2418 (.000010 MIN. THK.)
CONTACTS _____ GOLD PER ASTM-B-488, TYPE I, CODE C, CLASS 0.75
(.000030 MIN. THK.) OVER NICKEL PER SAE AMS QQ-N-290 CLASS 1
(.000050 MIN. THK.) OVER COPPER PER AMS 2418 (.000010 MIN. THK.)
INSULATORS & O-RINGS _____ N/A