

SPECIFICATION CONTROL DRAWING

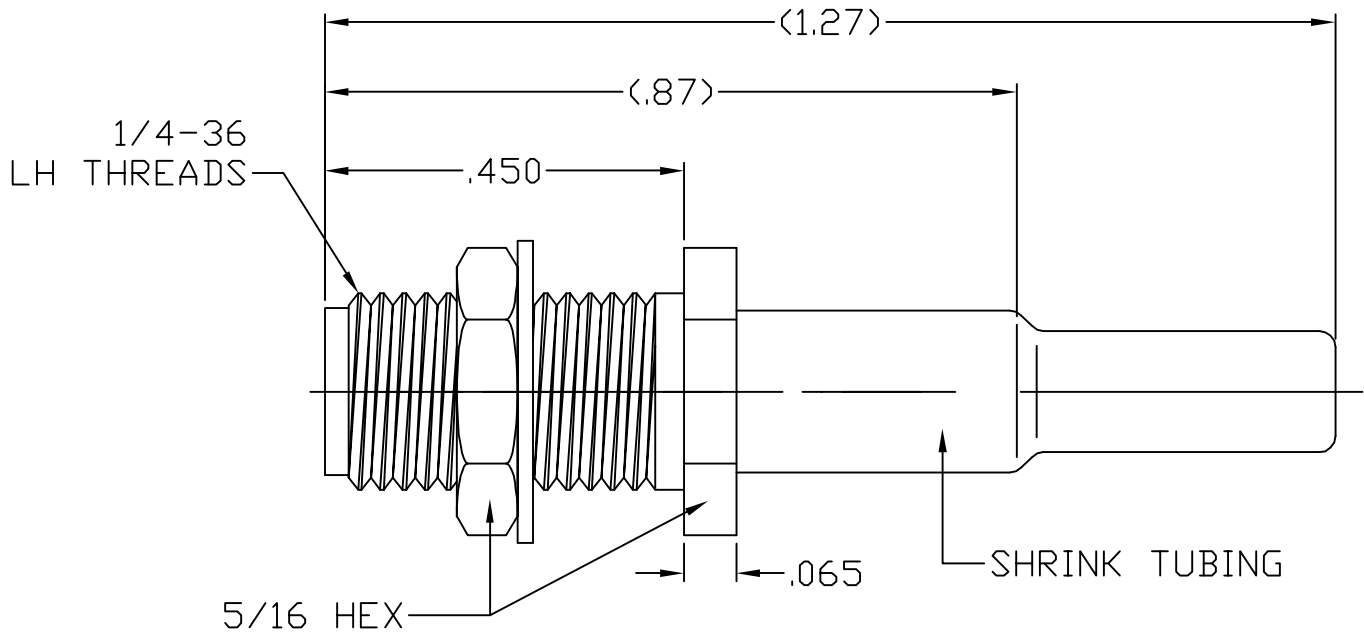

1. MATING INTERFACE DIMENSIONS Per MIL-STD-348 Fig. 310.2 (SMA JACK).

2. ELECTRICAL

FREQUENCY RANGE GHz	_____	DC TO 3.0 GHz
VSWR (MAX.) *	_____	1.07 + .010 x FGHz
INSERTION LOSS (dB MAX.) *	_____	.04 dB x $\sqrt{\text{FGHz}}$
NOMINAL IMPEDANCE (OHMS)	_____	50
VOLTAGE RATING (MAX. VRMS)	_____	250
RF LEAKAGE (MIN. dB DOWN)	_____	-100 dB - FGHz
TEMPERATURE RATING (DEGREES CENTIGRADE)	_____	-65°c TO + 165°c
DIELECTRIC WITHSTANDING VOLTAGE (MAX. VRMS)	_____	750
INSULATION RESISTANCE (MIN. MEGOHMS)	_____	5,000
CONTACT RESISTANCE		
• CENTER CONTACT (MAX. MILLIOHMS)	_____	6.0
• OUTER CONTACT (MAX. MILLIOHMS)	_____	2.0

* TERMINATED IN A 50 OHM LOAD

REV.	DCN NO.	DATE	APP.	DIMENSIONS ARE IN INCHES TOLERANCES			 HAVERHILL, MA 01835
AA	07-1090	1/26/07	DC	DECIMALS	FRACTIONAL	ANGULAR	
				.X ± .030	± 1/64	X ° ± 1'0"	TITLE SMA JACK, BULKHEAD, CRIMP TO RG-316 CABLE LEFT HAND THREADS
				.XX ± .010		X ° X ± 15'	
				.XXX ± .005			
				DRAWN DC	DATE 1/26/07		
				APPROVED DC	DATE 1/26/07		
				CODE IDENT.	SHEET 1 OF 2	DWG. NO. 9910-1630-2402	
				2J899			

SPECIFICATION CONTROL DRAWING

3. MECHANICAL

CAPTIVATION-CENTER CONTACT

MAX AXIAL FORCE _____ N/A

MAX RADIAL TORQUE _____ N/A

CENTER CONTACT AXIAL FORCES

● INSERTION (MAX OUNCES) _____ INTERFACE 32.0

● WITHDRAWAL (MIN. OUNCES) _____ INTERFACE 2.0

CONNECTOR ENGAGEMENT/DISENGAGEMENT (MAX IN. LBS.) — 2.0

CONNECTOR DURABILITY (MIN. CYCLES) _____ 500

RECOMMENDED MATING TORQUE _____ 7 - 10 IN. LBS.

4. ENVIRONMENTAL

TEMPERATURE CYCLING _____ MIL-STD-202, METHOD 102, COND. C (-65° c TO + 200° c)

SHOCK _____ MIL-STD-202, METHOD 213, COND. I (100 G's)

VIBRATION _____ MIL-STD-202, METHOD 204, COND. D (20 G's)

MOISTURE RESISTANCE _____ MIL-STD-202, METHOD 106, LESS STEP 7b

CORROSION _____ MIL-STD-202, METHOD 101, COND. B (48 HOURS)

BAROMETRIC PRESSURE (ALTITUDE) _____ MIL-STD-202, METHOD 105, COND. C (70,000 FT.) (190 VRMS)

5. MATERIAL

BODY & HEX NUT _____ BRASS PER ASTM-B16, TEMPER H02, ALLOY C36000

CONTACT _____ BERYLLIUM COPPER PER ASTM B196-90, COPPER ALLOY
No. UNS-C17300, TEMPER TD04.

INSULATOR _____ TEFLON PER ASTM D 4894-91.

CRIMP SLEEVE _____ BRASS PER ASTM-B16, TEMPER H02, ALLOY C36000

SHRINK TUBING _____ POLYOLEFIN PER MIL-DTL-23053/5-105-9 (WHITE)

6. FINISH

BODY & HEX NUT _____ GOLD PER ASTM-B-488, TYPE I, CODE C, CLASS 1.25
(.000050 MIN. THK.) OVER NICKEL per QQ-N-290
(.000150 MIN. THK.) OVER COPPER per MIL-C-14550
(.000010 MIN. THK.)

CRIMP SLEEVE _____ NICKEL PER QQ-N-290, CLASS 1
(.000200 MIN. THK.) OVER COPPER per MIL-C-14550
(.000010 MIN. THK.)

CONTACT _____ GOLD PER ASTM-B-488, TYPE I, CODE C, CLASS 2.5
(.000100 MIN. THK.) OVER NICKEL per QQ-N-290
(.000050 MIN. THK.) OVER COPPER per MIL-C-14550
(.000010 MIN. THK.)

INSULATOR & TUBING _____ N/A



SHEET 2 OF 2

DWG.
NO.

9910-1630-2402

REV.

AA