

SPECIFICATION CONTROL DRAWING

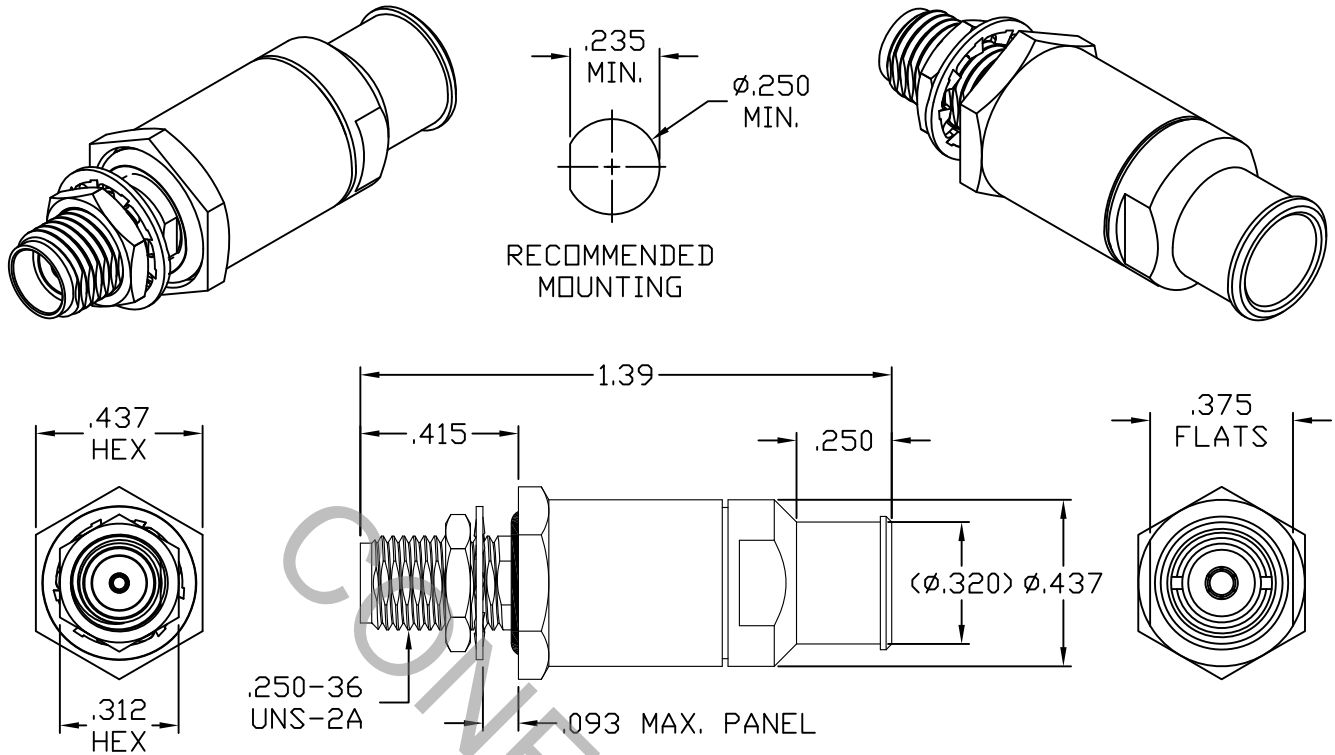

1. MATING INTERFACE DIMENSIONS Per MIL-STD-348 Fig. 310.2 (SMA JACK).

2. ELECTRICAL

FREQUENCY RANGE GHz	_____	DC TO 26.5 GHz
VSWR (MAX.) *	_____	1.05 + .006 x FGHz
INSERTION LOSS (dB MAX.) *	_____	.05 dB x √FGHz
NOMINAL IMPEDANCE (OHMS)	_____	50
VOLTAGE RATING (MAX. VRMS)	_____	400
RF LEAKAGE (MIN. dB DOWN)	_____	-100 dB - FGHz
TEMPERATURE RATING (DEGREES CENTIGRADE)	_____	-65°c TO + 148°c
DIELECTRIC WITHSTANDING VOLTAGE (MAX. VRMS)	_____	1,250
INSULATION RESISTANCE (MIN. MEGOHMS)	_____	5,000
CONTACT RESISTANCE		
• CENTER CONTACT (MAX. MILLIOHMS)	_____	6.0
• OUTER CONTACT (MAX. MILLIOHMS)	_____	2.0

* TERMINATED IN A 50 OHM LOAD

This Document contains proprietary and confidential information.

RoHS
COMPLIANT

REV.	DCN NO.	DATE	APP.	DIMENSIONS ARE IN INCHES TOLERANCES			CABLE INCORPORATED HAVERHILL, MA 01835
				DECIMALS	FRACTIONAL	ANGULAR	
AA	13-1740	5/17/13	DC	.X ± .030 .XX ± .010 .XXX ± .005	± 1/64	X ° ± 1'0" X ° X' ± 15'	
AB	13-2079	8/2/13	DC				
				DRAWN	RMS	DATE	TITLE SMA JACK, BULKHEAD, SOLDER CLAMP, PLUG-IN FOR DF226W LOW LOSS CABLE
				APPROVED	DC	DATE	
				CODE IDENT.		SHEET	DWG. NO. 9910-226W-6240
				6DZL5		1 OF 2	

SPECIFICATION CONTROL DRAWING

3. MECHANICAL

CAPTIVATION-CENTER CONTACT
MAX AXIAL FORCE _____ 6.0 LBS.
MAX RADIAL TORQUE _____ N/A
CENTER CONTACT AXIAL FORCES
● INSERTION (MAX OUNCES) _____ 40.0
● WITHDRAWAL (MIN. OUNCES) _____ 2.0
CONNECTOR ENGAGEMENT/DISENGAGEMENT (MAX. LBS.) _____ 2.0
CONNECTOR DURABILITY (MIN. CYCLES) _____ 500
RECOMMENDED MATING TORQUE _____ 7 - 10 IN. LBS.
RECOMMENDED MOUNTING TORQUE _____ 18 - 22 IN. LBS.

4. ENVIRONMENTAL

TEMPERATURE CYCLING _____ MIL-STD-202, METHOD 107, COND. C (-65° c TO +148° c)
SHOCK _____ MIL-STD-202, METHOD 213, COND. I (100 G's)
VIBRATION _____ MIL-STD-202, METHOD 204, COND. D (20 G's)
MOISTURE RESISTANCE _____ MIL-STD-202, METHOD 106, LESS STEP 7b
CORROSION _____ MIL-STD-202, METHOD 101, COND. B (48 HOURS)
BAROMETRIC PRESSURE (ALTITUDE) _____ MIL-STD-202, METHOD 105, COND. C (70,000 FT.) (300 VRMS)

5. MATERIAL

BODY, HEX NUT, CLAMP NUT & _____ STAINLESS STEEL PER ASTM-A-582, TYPE 303, COND. A
PRESS SLEEVE
LOCKWASHER _____ 400 SERIES STAINLESS STEEL
CONTACTS _____ BERYLLIUM COPPER PER ASTM-B-196/B, 196M-03, COPPER
ALLOY No. UNS-C17300, TEMPER TD04.
FRONT INSULATOR _____ TEFLON PER ASTM D-1710-02, TYPE 1, GRADE 1, CLASS B.
REAR INSULATOR _____ CROSS LINKED POLYETHYLENE (400° F)
O-RINGS _____ SILICONE RUBBER PER ZZ-R-765.
SOLDER SLEEVE _____ BRASS PER ASTM-B-16, TEMPER H02, ALLOY C36000.

6. FINISH

BODY, HEX NUT, CLAMP NUT, LOCKWASHER & _____ PASSIVATE PER AMS 2700, TYPE 2, CLASS 4.
PRESS SLEEVE
SOLDER SLEEVE _____ GOLD PER ASTM-B-488, TYPE I, CODE C, CLASS 1.27
(.000050 MIN. THK.) OVER NICKEL PER SAE AMS QQ-N-290 CLASS 1
(.000150 MIN. THK.) OVER COPPER PER AMS 2418 (.000010 MIN. THK.)
CONTACTS _____ GOLD PER ASTM-B-488, TYPE I, CODE C, CLASS 0.75
(.000030 MIN. THK.) OVER NICKEL PER SAE AMS QQ-N-290 CLASS 1
(.000050 MIN. THK.) OVER COPPER PER AMS 2418 (.000010 MIN. THK.)
INSULATORS & O-RINGS _____ N/A