

SPECIFICATION CONTROL DRAWING

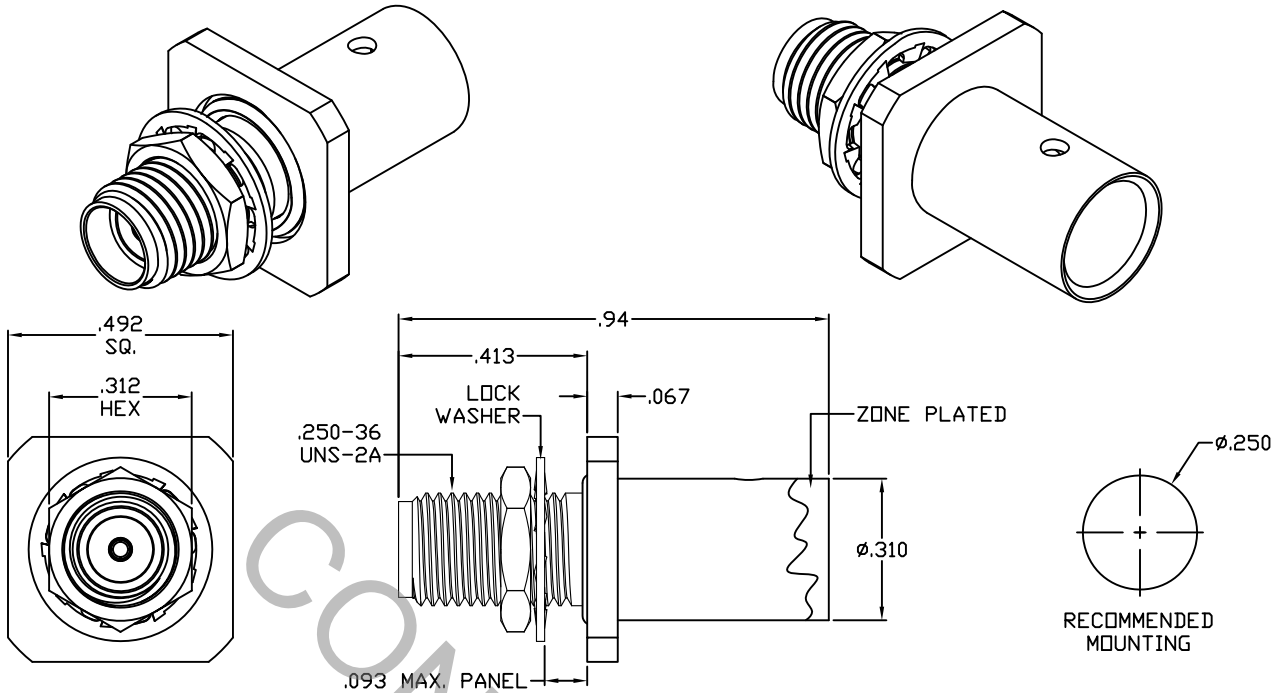

1. MATING INTERFACE DIMENSIONS Per MIL-STD-348 Fig. 310.2 (SMA JACK).

2. ELECTRICAL

FREQUENCY RANGE GHz	_____	DC TO 18.0 GHz
VSWR (MAX) *	_____	1.06 + .007 x FGHz
INSERTION LOSS (dB MAX) *	_____	.04 dB x $\sqrt{\text{FGHz}}$
NOMINAL IMPEDANCE (OHMS)	_____	50
VOLTAGE RATING (MAX. VRMS)	_____	417
RF LEAKAGE (MIN. dB DOWN)	_____	-100 dB - FGHz
TEMPERATURE RATING (DEGREES CENTIGRADE)	_____	-65°c TO + 165°c
DIELECTRIC WITHSTANDING VOLTAGE (MAX. VRMS)	_____	1,250
INSULATION RESISTANCE (MIN. MEGOHMS)	_____	5,000
CONTACT RESISTANCE		
• CENTER CONTACT (MAX. MILLIOHMS)	_____	6.0
• OUTER CONTACT (MAX. MILLIOHMS)	_____	2.0

* TERMINATED IN A 50 OHM LOAD

This Document contains proprietary and confidential information.

RoHS
COMPLIANT

REV.	DCN NO.	DATE	APP.	DIMENSIONS ARE IN INCHES TOLERANCES				 HAVERHILL, MA 01835		
				DECIMALS	FRACTIONAL	ANGULAR				
AA	10-1407	4/20/10	TS	.X ± .030 .XX ± .010 .XXX ± .005	± 1/64	X ° ± 1'0" X ° X' ± 15'				
AB	10-1433	4/29/10	DC							
BA	10-1528	6/3/10	DC	DRAWN	TS	DATE	4/20/10	TITLE SMA JACK, BULKHEAD, DIRECT SOLDER, ϕ .250 S/R		
BB	13-2080	8/2/13	DC							
				APPROVED	DC	DATE	4/20/10			
				CODE IDENT.					DWG. NO. 9910-2520-6800	
				2J899	SHEET 1 OF 2					

SPECIFICATION CONTROL DRAWING

3. MECHANICAL

CAPTIVATION-CENTER CONTACT

MAX AXIAL FORCE _____ N/A

MAX RADIAL TORQUE _____ N/A

CENTER CONTACT AXIAL FORCES

● INSERTION (MAX OUNCES) _____ INTERFACE 32.0

● WITHDRAWAL (MIN. OUNCES) _____ INTERFACE 2.0

CONNECTOR ENGAGEMENT/DISENGAGEMENT (MAX LBS.) _____ 2.0

CONNECTOR DURABILITY (MIN. CYCLES) _____ 500

RECOMMENDED MATING TORQUE _____ 7 - 10 IN. LBS.

RECOMMENDED MOUNTING TORQUE _____ 18 - 22 IN. LBS.

4. ENVIRONMENTAL

TEMPERATURE CYCLING _____ MIL-STD-202, METHOD 107, COND. C (-65° c TO + 165° c)

SHOCK _____ MIL-STD-202, METHOD 213, COND. I (100 G's)

VIBRATION _____ MIL-STD-202, METHOD 204, COND. D (20 G's)

MOISTURE RESISTANCE _____ MIL-STD-202, METHOD 106, LESS STEP 7b

CORROSION _____ MIL-STD-202, METHOD 101, COND. B (48 HOURS)

BAROMETRIC PRESSURE (ALTITUDE) _____ MIL-STD-202, METHOD 105, COND. C (70,000 FT.) (313 VRMS)

5. MATERIAL

BODY & HEX NUT _____ STAINLESS STEEL PER ASTM-A-582, TYPE 303, COND. A

LOCKWASHER _____ STAINLESS STEEL PER ASTM-A-479, TYPE 410.

CONTACT _____ BERYLLIUM COPPER PER ASTM-B-196/B, 196M-03, COPPER ALLOY No. UNS-C17300, TEMPER TD04.

INSULATOR _____ TEFLON PER ASTM D-1710-02, TYPE 1, GRADE 1, CLASS B.

O-RING _____ NITRILE (BUNA-N)

6. FINISH

BODY, LOCKWASHER & HEX NUT _____ PASSIVATE PER AMS 2700, TYPE 2, CLASS 4.

BODY ZONE PLATING _____ GOLD PER ASTM-B-488, TYPE I, CODE C, CLASS 1.25
(.000050 MIN. THK.) OVER NICKEL per QQ-N-290
(.000150 MIN. THK.) OVER COPPER per MIL-C-14550
(.000010 MIN. THK.)

CONTACT _____ GOLD PER ASTM-B-488, TYPE I, CODE C, CLASS 2.5
(.000100 MIN. THK.) OVER NICKEL per QQ-N-290
(.000050 MIN. THK.) OVER COPPER per MIL-C-14550
(.000010 MIN. THK.)

INSULATOR & O-RING _____ N/A