

SPECIFICATION CONTROL DRAWING

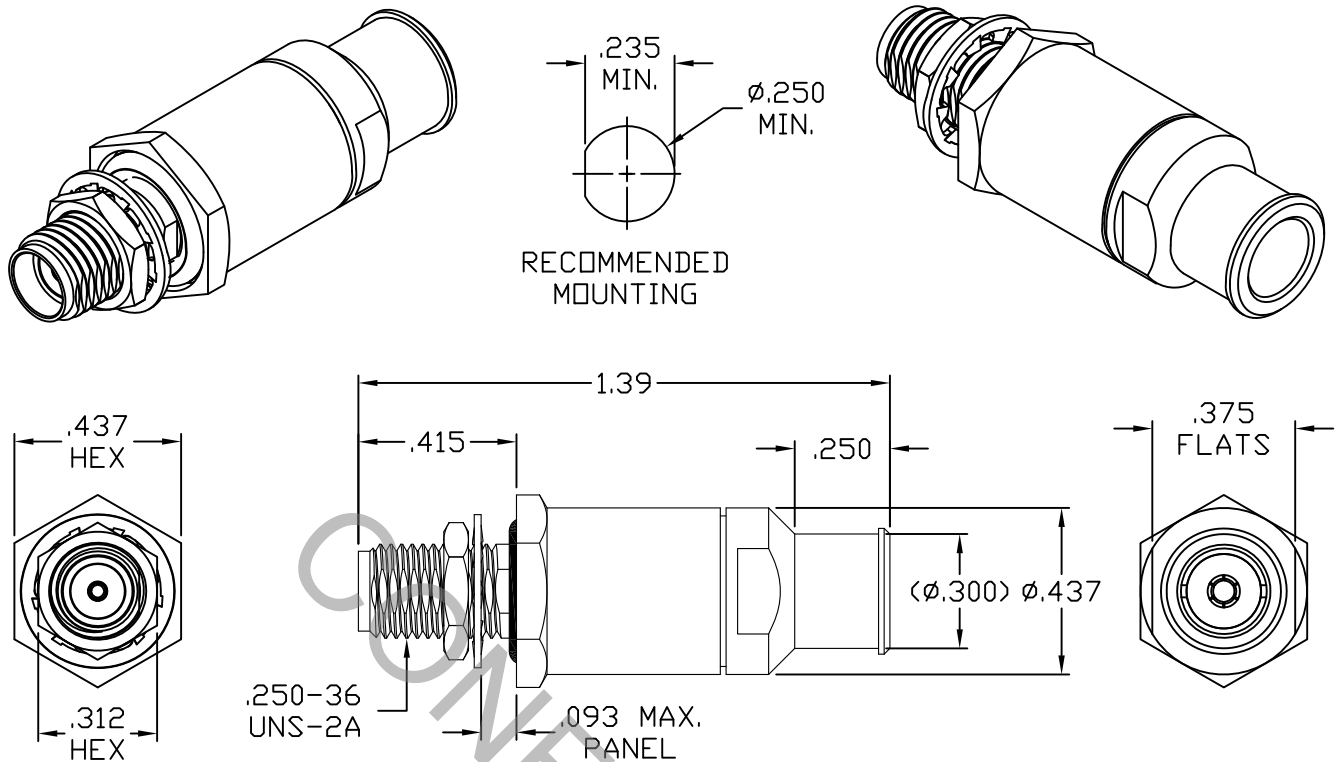

1. MATING INTERFACE DIMENSIONS Per MIL-STD-348 Fig. 310.2 (SMA JACK).

2. ELECTRICAL

FREQUENCY RANGE GHz	_____	DC TO 18.0 GHz
VSWR (MAX.) *	_____	1.05 + .006 x FGHz
INSERTION LOSS (dB MAX.) *	_____	.05 dB x $\sqrt{\text{FGHz}}$
NOMINAL IMPEDANCE (OHMS)	_____	50
VOLTAGE RATING (MAX. VRMS)	_____	400
RF LEAKAGE (MIN. dB DOWN)	_____	-100 dB - FGHz
TEMPERATURE RATING (DEGREES CENTIGRADE)	_____	-65°C TO + 148°C
DIELECTRIC WITHSTANDING VOLTAGE (MAX. VRMS)	_____	1,250
INSULATION RESISTANCE (MIN. MEGOHMS)	_____	5,000
CONTACT RESISTANCE		
• CENTER CONTACT (MAX. MILLIOHMS)	_____	6.0
• OUTER CONTACT (MAX. MILLIOHMS)	_____	2.0

* TERMINATED IN A 50 OHM LOAD

RoHS
COMPLIANT

This Document contains proprietary and confidential information.

REV.	DCN NO.	DATE	APP.	DIMENSIONS ARE IN INCHES TOLERANCES			CABLE INCORPORATED HAVERHILL, MA 01835	
				DECIMALS	FRACTIONAL	ANGULAR		
AA	12-1604	7/26/12	TS	.X ± .030 .XX ± .010 .XXX ± .005	± 1/64	X ° ± 1'0" X ° X' ± 15'	TITLE SMA JACK, BULKHEAD, SOLDER CLAMP, PLUG-IN FOR T7-00015 LOW LOSS CABLE	
AB	12-1785	9/11/12	DC					
AC	12-2190	11/29/12	DC	DRAWN TS DATE 7/26/12				
AD	13-2084	8/2/13	DC	APPROVED DC DATE 7/26/12				
				CODE IDENT. 6DZL5	SHEET 1 OF 2		DWG. NO. 9910-7015-6240	

SPECIFICATION CONTROL DRAWING

3. MECHANICAL

CAPTIVATION-CENTER CONTACT
MAX AXIAL FORCE _____ 6.0 LBS.
MAX RADIAL TORQUE _____ N/A
CENTER CONTACT AXIAL FORCES
● INSERTION (MAX OUNCES) _____ 40.0
● WITHDRAWAL (MIN. OUNCES) _____ 2.0
CONNECTOR ENGAGEMENT/DISENGAGEMENT (MAX. LBS.) _____ 2.0
CONNECTOR DURABILITY (MIN. CYCLES) _____ 500
RECOMMENDED MATING TORQUE _____ 7 - 10 IN. LBS.
RECOMMENDED MOUNTING TORQUE _____ 18 - 22 IN. LBS.

4. ENVIRONMENTAL

TEMPERATURE CYCLING _____ MIL-STD-202, METHOD 107, COND. C (-65° c TO +148° c)
SHOCK _____ MIL-STD-202, METHOD 213, COND. I (100 G's)
VIBRATION _____ MIL-STD-202, METHOD 204, COND. D (20 G's)
MOISTURE RESISTANCE _____ MIL-STD-202, METHOD 106, LESS STEP 7b
CORROSION _____ MIL-STD-202, METHOD 101, COND. B (48 HOURS)
BAROMETRIC PRESSURE (ALTITUDE) _____ MIL-STD-202, METHOD 105, COND. C (70,000 FT.) (300 VRMS)

5. MATERIAL

BODY, BUSHING, HEX NUT & CLAMP NUT _____ STAINLESS STEEL PER ASTM-A-582, TYPE 303, COND. A
LOCKWASHER _____ 400 SERIES STAINLESS STEEL
CONTACT _____ BERYLLIUM COPPER PER ASTM-B-196/B, 196M-03, COPPER ALLOY No. UNS-C17300, TEMPER TD04.
FRONT INSULATOR _____ TEFLON PER ASTM D-1710-02, TYPE 1, GRADE 1, CLASS B.
REAR INSULATOR _____ CROSS LINKED POLYETHYLENE (204° C)
O-RING _____ SILICONE RUBBER PER ZZ-R-765.
SOLDER SLEEVE _____ BRASS PER ASTM-B-16, TEMPER H02, ALLOY C36000.

6. FINISH

BODY, BUSHING, HEX NUT, LOCKWASHER AND CLAMP NUT _____ PASSIVATE PER AMS 2700, TYPE 2, CLASS 4.
SOLDER SLEEVE _____ GOLD PER ASTM-B-488, TYPE I, CODE C, CLASS 1.25 (.000050 MIN. THK.) OVER NICKEL PER SAE AMS QQ-N-290 CLASS 1 (.000150 MIN. THK.) OVER COPPER PER AMS 2418 (.000010 MIN. THK.)
CONTACT _____ GOLD PER ASTM-B-488, TYPE I, CODE C, CLASS 1.27 (.000050 MIN. THK.) OVER NICKEL PER SAE AMS QQ-N-290 CLASS 1 (.000050 MIN. THK.) OVER COPPER PER AMS 2418 (.000010 MIN. THK.)
INSULATORS & O-RING _____ N/A