

CONNECTOR SERIES: : SMA
 CENTER CONTACT: : MALE PIN
 NOMINAL IMPEDANCE: (OHMS) : 50
 CABLE ACCOMMODATION: : RG-405
 : Ø.085 S/R
 : T-FLEX-405
 CONTACT CAPTIVATION: : N/A
 CABLE ATTACHMENT: : SOLDER
 CONTACT ATTACHMENT: : SOLDER
 FREQUENCY RANGE: : DC TO 6.0 GHz.
 QPL SPECIFICATION: : N/A
 QPL EQUIVALENT: : N/A

MATING CHARACTERISTICS : COMMERCIAL
 MATING TORQUE : 5 TO 7 POUND INCHES
 MOUNTING TORQUE : N/A
 TEMPERATURE RANGE : -55 / +125 DEGREES C.

ELECTRICAL:
 VSWR MAXIMUM : 1.06 x F^{.05} (F IN GHz.)
 INSERTION LOSS MAXIMUM : .040 √FGHz.
 R.F. LEAKAGE MINIMUM : -100 dB
 INSULATION RESISTANCE : 5,000 MEGOHMS MIN.
 D.W.V. : 750 VRMS MAX.

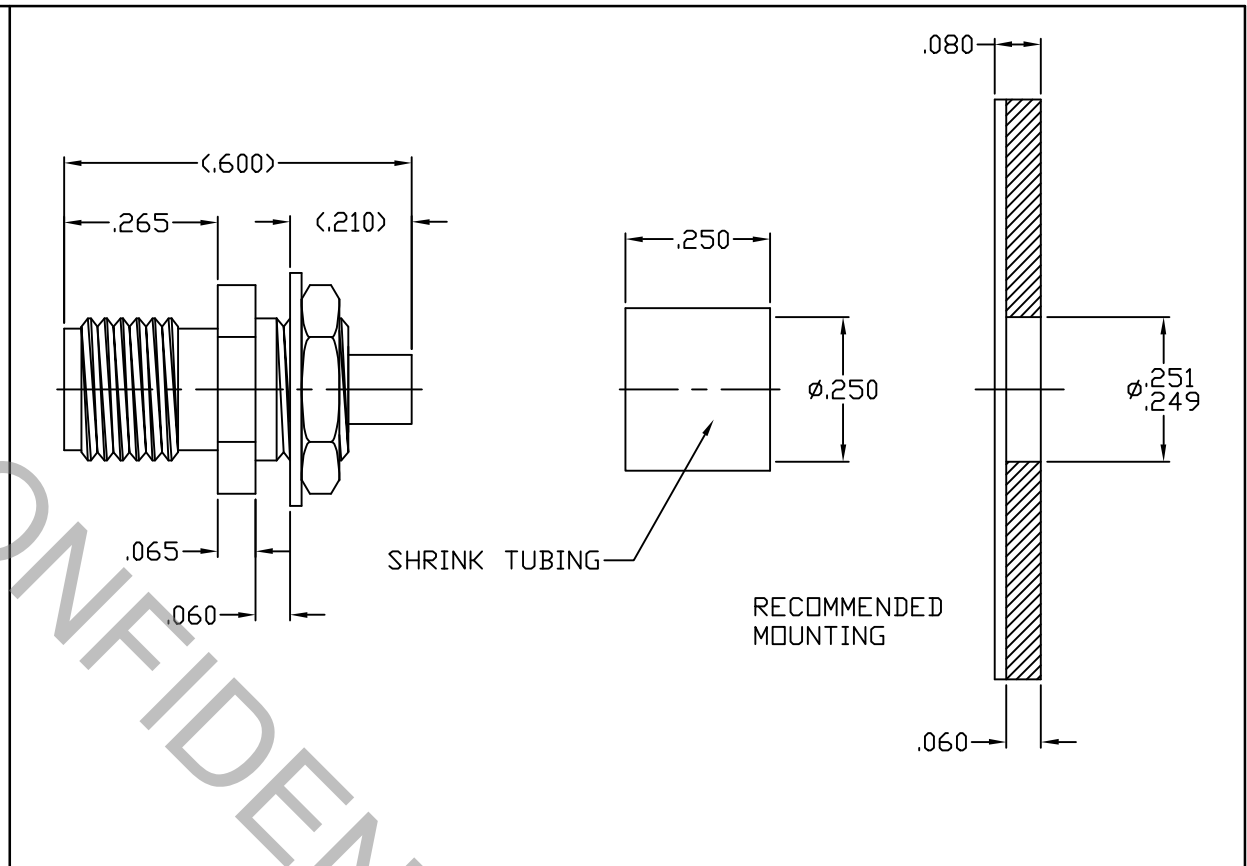

ITEM	MATERIALS	FINISHES
BODY	: BRASS PER ASTM-B-16	: NICKEL PER QQ-N-290
LOCKNUT	: BRASS PER ASTM-B-16	: NICKEL PER QQ-N-290
LOCKWASHER	: PHOSPHOR BRONZE	: NICKEL PER QQ-N-290
INSULATOR	: PTFE PER ASTM-D-1710	: N/A
CONTACT	: BRASS PER ASTM-B-16	: GOLD PER ASTM-B-488

REV.	DCN NUMBER	DATE	APP.
AA	04-1684	5/24/04	DC

SPECIFICATION CONTROL DRAWING



TITLE
**SMA BULKHEAD JACK,
 POLARIZED, CRIMP
 FOR Ø.085 SEMI-RIGID**

TOLERANCES		
DECIMALS	FRACTIONAL	DEGREES
.X ±.030	± 1/16"	X° ±1°
.XX ±.010		X°X' ±15'
.XXX ±.005		

DRAWN: DC DATE: 5/24/04
 APPROVED: DC DATE: 5/24/04

SCALE	CODE IDENT	SHEET
N/A	2J899	1 of 1

DRAWING
 NO. **9910-8520-2700**