

# SPECIFICATION CONTROL DRAWING

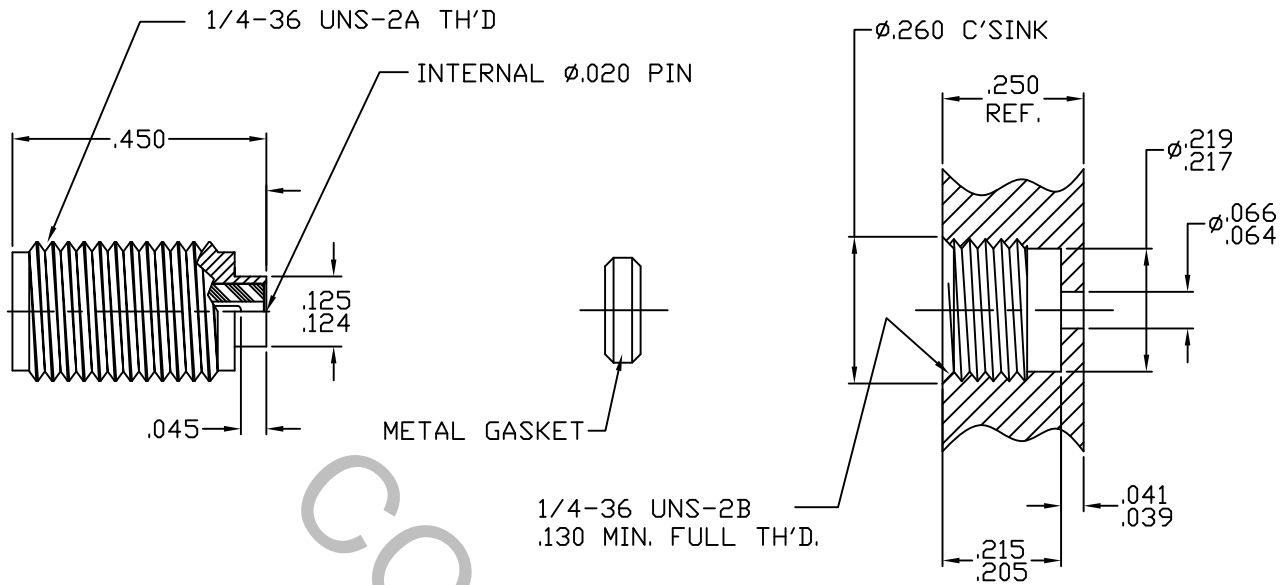

1. MATING INTERFACE DIMENSIONS PER MIL-STD-348, Fig. 310-2 (SMA, JACK)

## 2. ELECTRICAL

FREQUENCY RANGE GHz	_____	DC TO 26.5 GHz
VSWR (MAX) *	_____	1.04 + .008 x FGHz.
INSERTION LOSS (dB MAX.)	_____	.04 dB x $\sqrt{\text{FGHz}}$
NOMINAL IMPEDANCE (OHMS)	_____	50
VOLTAGE RATING (MAX. VRMS)	_____	250
RF LEAKAGE (MIN. dB DOWN)	_____	100 dB - FGHz
TEMPERATURE RATING (DEGREES CENTIGRADE)	_____	-65°c TO + 165°c
DIELECTRIC WITHSTANDING VOLTAGE (MAX. VRMS)	_____	750
INSULATION RESISTANCE (MIN. MEGOHMS)	_____	10,000
CONTACT RESISTANCE		
• CENTER CONTACT (MAX. MILLIOHMS)	_____	12.0
• OUTER CONTACT (MAX. MILLIOHMS)	_____	2.0

\* TERMINATED IN A 50 OHM LOAD

**RoHS**  
COMPLIANT

REV.	DCN NO.	DATE	APP.	DIMENSIONS ARE IN INCHES TOLERANCES			 HAVERHILL, MA. 01835
				DECIMALS	FRACTIONAL	ANGULAR	
AA	09-1086	1/30/09	TS	.X ± .030 .XX ± .010 .XXX ± .005	±/64	X ° ± 1 0' X ° X' ± 15'	TITLE SMA, JACK SPARK PLUG HERMETICALLY SEALED with METAL GASKET
AB	09-1749	9/29/09	DC				
				DRAWN	TS	DATE	1/30/09
				APPROVED	DC	DATE	1/30/09
				CODE IDENT.			DWG. NO. 9930-0441-6200
				2J899	SHEET 1 OF 2		

# SPECIFICATION CONTROL DRAWING

## 3. MECHANICAL

### CAPTIVATION-CENTER CONTACT

MAX AXIAL FORCE \_\_\_\_\_ 4.5 LBS.

MAX RADIAL TORQUE \_\_\_\_\_ N/A

### CENTER CONTACT AXIAL FORCES

● INSERTION (MAX OUNCES) \_\_\_\_\_ 48.0

● WITHDRAWAL (MIN. OUNCES) \_\_\_\_\_ 2.0

CONNECTOR ENGAGEMENT/DISENGAGEMENT (MAX IN. LBS.) \_\_\_\_\_ 2.0

CONNECTOR DURABILITY (MIN. CYCLES) \_\_\_\_\_ 500

### RECOMMENDED MATING TORQUE

● INTERFACE \_\_\_\_\_ 7 - 10 IN. LBS.

● PACKAGE \_\_\_\_\_ 20 - 23 IN. LBS.

## 4. ENVIRONMENTAL

TEMPERATURE CYCLING \_\_\_\_\_ MIL-STD-202, METHOD 102, COND. C ( -65° c TO +200° c )

SHOCK \_\_\_\_\_ MIL-STD-202, METHOD 213, COND. I (100 G's)

VIBRATION \_\_\_\_\_ MIL-STD-202, METHOD 204, COND. D (20 G's)

MOISTURE RESISTANCE \_\_\_\_\_ MIL-STD-202, METHOD 106, LESS STEP 7b

CORROSION \_\_\_\_\_ MIL-STD-202, METHOD 101, COND. B (48 HOURS)

BAROMETRIC PRESSURE (ALTITUDE) \_\_\_\_\_ MIL-STD-202, METHOD 105, COND. C ( 70,000 FT. ) ( 190 VRMS )

HERMETICITY \_\_\_\_\_  $1 \times 10^{-8}$  cc/SEC.

## 5. MATERIAL

BODY \_\_\_\_\_ STAINLESS STEEL PER ASTM 582, TYPE 303, COND. A

CONTACT \_\_\_\_\_ BERYLLIUM COPPER PER ASTM B196/B, 196M-03, COPPER ALLOY No. UNS 17300, TEMPER TDO4.

INSULATOR \_\_\_\_\_ TEFLON PER ASTM D 1710-02, TYPE 1, GRADE 1, CLASS B.

GLASS PIN \_\_\_\_\_ KOVAR PER MIL-I-23011

GLASS \_\_\_\_\_ CORNING 7070

METAL GASKET \_\_\_\_\_ CARBON STEEL PER B1113, CASE HARDENED

## 6. FINISH

BODY \_\_\_\_\_ PASSIVATE PER AMS QQ-P-35, TYPE 2.

GLASS PIN \_\_\_\_\_ GOLD PER ASTM-B-488, TYPE 1, CODE C, CLASS 1.25  
(.000050 MIN. THK.) OVER NICKEL PER QQ-N-290  
(.000050 MIN. THK.) OVER COPPER per MIL-C-14550  
(.000010 MIN. THK.)

CONTACT \_\_\_\_\_ GOLD PER ASTM-B-488, TYPE 1, CODE C, CLASS 2.5  
(.000100 MIN. THK.) OVER NICKEL PER QQ-N-290  
(.000050 MIN. THK.) OVER COPPER per MIL-C-14550  
(.000010 MIN. THK.)

METAL GASKET \_\_\_\_\_ NICKEL PER SAE-AMS-2404 (.0001 MIN. THK.) OVER  
COPPER PER SAE-AMS-2418-1 (.0001 MIN. THK.).

GLASS AND INSULATOR \_\_\_\_\_ N/A