

# SPECIFICATION CONTROL DRAWING

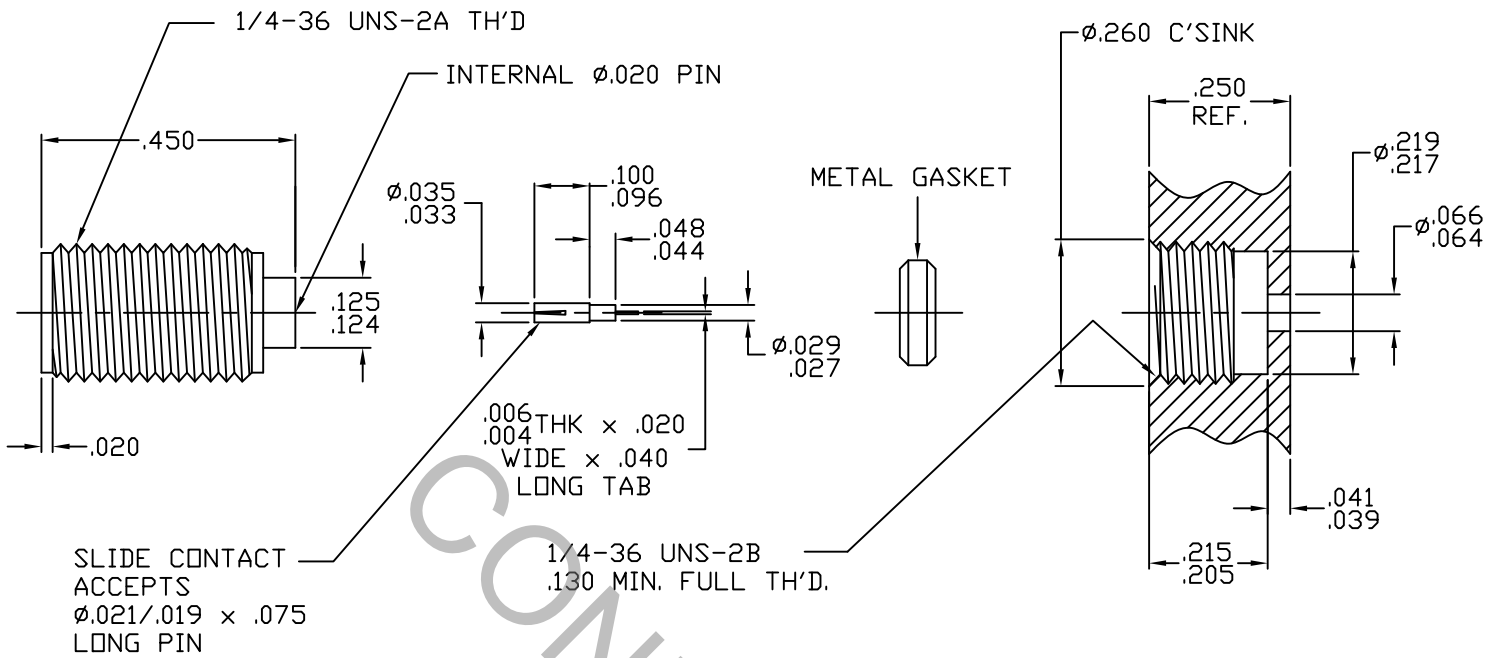

1. MATING INTERFACE DIMENSIONS FOR SMA JACK per MIL-STD-348 (Fig. 310-2).

## 2. ELECTRICAL

FREQUENCY RANGE GHz	_____	DC TO 26.5 GHz
VSWR (MAX) *	_____	1.04 + .008 x FGHz.
INSERTION LOSS (dB MAX)	_____	.04 dB x $\sqrt{\text{FGHz}}$
NOMINAL IMPEDANCE (OHMS)	_____	50
VOLTAGE RATING (MAX. VRMS)	_____	250
RF LEAKAGE (MIN. dB DOWN)	_____	100 dB - FGHz
TEMPERATURE RATING (DEGREES CENTIGRADE)	_____	-65°c TO + 165°c
DIELECTRIC WITHSTANDING VOLTAGE (MAX. VRMS)	_____	750
INSULATION RESISTANCE (MIN. MEGOHMS)	_____	10,000
CONTACT RESISTANCE		
• CENTER CONTACT (MAX. MILLIOHMS)	_____	12.0
• OUTER CONTACT (MAX. MILLIOHMS)	_____	2.0

\* TERMINATED IN A 50 OHM LOAD

**RoHS**  
COMPLIANT

This Document contains proprietary and confidential information.

REV.	DCN NO.	DATE	APP.	DIMENSIONS ARE IN INCHES TOLERANCES				 HAVERHILL, MA. 01835	
-	205	10/86	CM	DECIMALS	FRACTIONAL	ANGULAR			
				.X ± .030 .XX ± .010 .XXX ± .005	±/64	X ° ± 10' X ° X' ± 15'			
A	530	1/88	DGG						
AA	11-1006	1/4/11	TS	DRAWN	CDM	DATE	10/86	TITLE SMA, JACK HERMETICALLY SEALED METAL GASKET	
AB	14-1479	4/17/14	DC	APPROVED	DGG	DATE	10/86		
				CODE IDENT.			SHEET 1 OF 2	DWG. NO.	9930-0441-6425
				2J899					

# SPECIFICATION CONTROL DRAWING

## 3. MECHANICAL

### CAPTIVATION-CENTER CONTACT

MAX AXIAL FORCE \_\_\_\_\_ 6.0 LBS.

MAX RADIAL TORQUE \_\_\_\_\_ N/A

### CENTER CONTACT AXIAL FORCES

● INSERTION (MAX OUNCES) \_\_\_\_\_ 48.0 INTERFACE; 32.0 SLIDE

● WITHDRAWAL (MIN. OUNCES) \_\_\_\_\_ 2.0 INTERFACE; 1.5 SLIDE

CONNECTOR ENGAGEMENT/DISENGAGEMENT (MAX IN. LBS.) — 2.0

CONNECTOR DURABILITY (MIN. CYCLES) \_\_\_\_\_ 500

### RECOMMENDED MATING TORQUE

● INTERFACE \_\_\_\_\_ 7 - 10 IN. LBS.

● PACKAGE \_\_\_\_\_ 20 - 23 IN. LBS.

## 4. ENVIRONMENTAL

TEMPERATURE CYCLING \_\_\_\_\_ MIL-STD-202, METHOD 102, COND. C ( -65° c TO +200° c )

SHOCK \_\_\_\_\_ MIL-STD-202, METHOD 213, COND. I (100 G's)

VIBRATION \_\_\_\_\_ MIL-STD-202, METHOD 204, COND. D (20 G's)

MOISTURE RESISTANCE \_\_\_\_\_ MIL-STD-202, METHOD 106, LESS STEP 7b

CORROSION \_\_\_\_\_ MIL-STD-202, METHOD 101, COND. B (48 HOURS)

BAROMETRIC PRESSURE (ALTITUDE) \_\_\_\_\_ MIL-STD-202, METHOD 105, COND. C ( 70,000 FT. ) ( 190 VRMS )

HERMETICITY \_\_\_\_\_  $1 \times 10^{-8}$  cc/SEC.

## 5. MATERIAL

BODY \_\_\_\_\_ STAINLESS STEEL PER ASTM-A-582, TYPE 303, COND. A

CONTACTS \_\_\_\_\_ BERYLLIUM COPPER PER ASTM-B-196/B, 196M-03, COPPER ALLOY No. UNS-C17300, TEMPER TD04.

INSULATOR \_\_\_\_\_ TEFLON PER ASTM-D-1710-02, TYPE 1, GRADE 1, CLASS B.

GLASS PIN \_\_\_\_\_ KOVAR PER MIL-I-23011

GLASS \_\_\_\_\_ CORNING 7070

METAL GASKET \_\_\_\_\_ CARBON STEEL PER B1113, CASE HARDENED

## 6. FINISH

GLASS PIN \_\_\_\_\_ GOLD PER ASTM-B-488, TYPE I, CODE C, CLASS 1.25 (.000050 MIN. THK.) OVER NICKEL PER SAE-AMS-QQ-N-290 CLASS 1 (.000150 MIN. THK.) OVER NICKEL (WOODS OR WATTS) (.000010 MIN. THK.)

CONTACT \_\_\_\_\_ GOLD PER ASTM-B-488, TYPE I, CODE C, CLASS 2.5 (.000100 MIN. THK.) OVER NICKEL LOW STRESS PER SAE-AMS-QQ-N-290, CLASS 2 (.000100 MIN. THK.) OVER COPPER PER SAE-AMS-2418-1 (.000100 TO .000300 THK.)

METAL GASKET \_\_\_\_\_ NICKEL PER MIL-C-26074, CLASS 1, (.000100 MIN. THK.) OVER COPPER PER AMS-2418, CLASS 4 (.000100 MIN. THK.).

GLASS AND INSULATOR \_\_\_\_\_ N/A

SLIDING CONTACT \_\_\_\_\_ GOLD PER ASTM-B-488, TYPE I, CODE C, CLASS 1.25 (.000050 - .000075 THK.) OVER NICKEL PER SAE-AMS-QQ-N-290, CLASS 1 (.00010 MIN. THK.) OVER COPPER PER AMS-2418 (.000040 MIN. THK.).