

SPECIFICATION CONTROL DRAWING

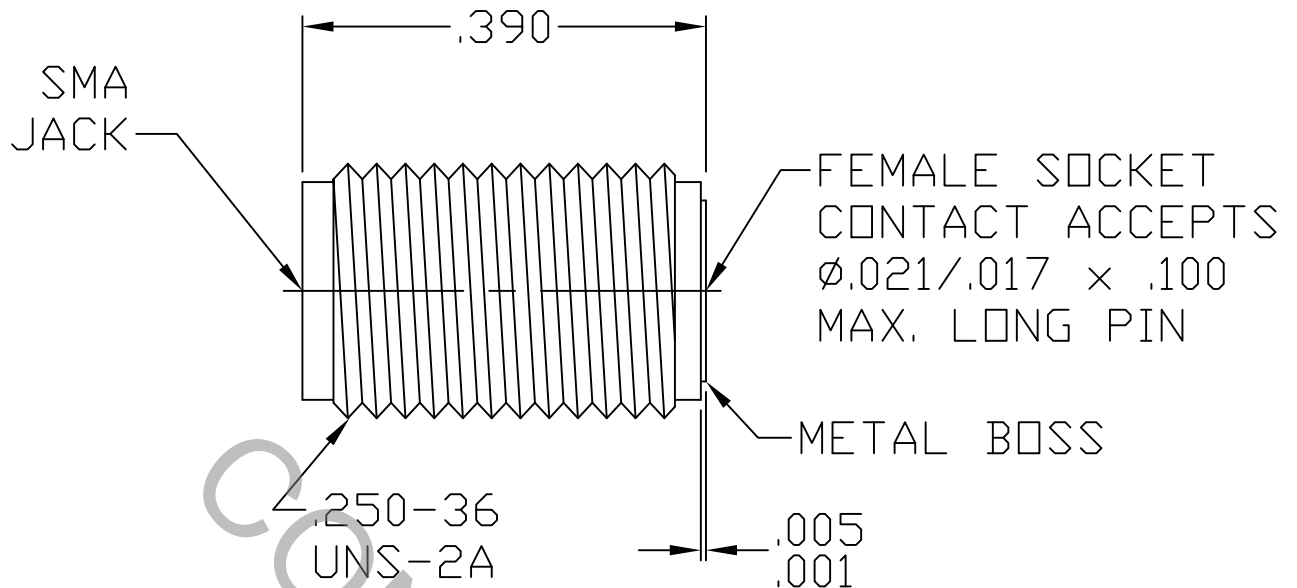

1. MATING INTERFACE DIMENSIONS FOR SMA JACK per MIL-STD-348 (Fig. 310-2).

2. ELECTRICAL

FREQUENCY RANGE GHz	DC TO 26.5 GHz.
VSWR (MAX.) *	1.05 + .004 x FGHz. TO 18 GHz. 1.05 + .006 x FGHz. 18 TO 26.5 GHz.
INSERTION LOSS (dB MAX.) *	.035 dB x $\sqrt{\text{FGHz}}$.
NOMINAL IMPEDANCE (OHMS)	50
VOLTAGE RATING (MAX. VRMS)	250
RF LEAKAGE (MIN. dB DOWN)	100 dB - FGHz.
TEMPERATURE RATING (DEGREES CENTIGRADE)	-65° c TO +165° c
DIELECTRIC WITHSTANDING VOLTAGE (MAX. VRMS)	750
INSULATION RESISTANCE (MIN. MEGOHMS)	10,000
CONTACT RESISTANCE	
• CENTER CONTACT (MAX. MILLIOHMS)	6.0
• OUTER CONTACT (MAX. MILLIOHMS)	2.0

* TERMINATED IN A 50 OHM LOAD

RoHS
COMPLIANT

This Document contains proprietary and confidential information.

REV.	DCN NO.	DATE	APP.	DIMENSIONS ARE IN INCHES TOLERANCES			 HAVERHILL, MA. 01835
				DECIMALS	FRACTIONAL	ANGULAR	
AA	06-1375	3/23/06	DC	.X ± .030 .XX ± .010 .XXX ± .005	± 1/64	X ° ± 1 0' X ° X' ± 15'	TITLE SMA, JACK SCREW-IN, FIELD REPLACEABLE WITH METAL BOSS
AB	16-1564	5/5/16	TS				
				DRAWN	TS	DATE 3/23/06	DWG. NO. 9930-0881-6281
				APPROVED	TS	DATE 3/23/06	
				CODE IDENT.			
				2J899	SHEET 1 OF 2		

SPECIFICATION CONTROL DRAWING

3. MECHANICAL

CAPTIVATION-CENTER CONTACT

MAX AXIAL FORCE _____ 4.5 LBS.

MAX RADIAL TORQUE _____ N/A

CENTER CONTACT AXIAL FORCES

● INSERTION (MAX. OUNCES) _____ INTERFACE 48.0; REAR 32.0

● WITHDRAWAL (MIN. OUNCES) _____ INTERFACE 2.0; REAR 1.0

CONNECTOR ENGAGEMENT/DISENGAGEMENT (MAX. IN. LBS.) — 2.0

CONNECTOR DURABILITY (MIN. CYCLES) _____ 500

RECOMMENDED MATING TORQUE

INTERFACE _____ 7 - 10 INCH LBS.

PACKAGE _____ 27 - 30 INCH LBS.

4. ENVIRONMENTAL

TEMPERATURE CYCLING _____ MIL-STD-202, METHOD 102, COND. C (-65° c TO +200° c)

SHOCK _____ MIL-STD-202, METHOD 213, COND. I (100 G's)

VIBRATION _____ MIL-STD-202, METHOD 204, COND. D (20 G's)

MOISTURE RESISTANCE _____ MIL-STD-202, METHOD 106, LESS STEP 7b

CORROSION _____ MIL-STD-202, METHOD 101, COND. B (48 HOURS)

BAROMETRIC PRESSURE (ALTITUDE) _____ MIL-STD-202, METHOD 105, COND. C (70,000 FT.) (190 VRMS)

5. MATERIAL

BODY _____ STAINLESS STEEL PER ASTM A 581, TYPE 303, COND. A

CONTACT _____ BERYLLIUM COPPER PER ASTM B196/B, 196M-03, COPPER ALLOY No. UNS-17300, TEMPER TD04.

INSULATOR _____ TEFLON PER ASTM D1710-02, TYPE 1, GRADE 1, CLASS B.

6. FINISH

BODY _____ PASSIVATE PER AMS 2700, TYPE 2, CLASS 4.

CONTACT _____ GOLD PER ASTM B 488, TYPE 1, CODE C, CLASS 1.25
(.000050 MIN. THK.) OVER NICKEL PER SAE AMS QQ-N-290, CLASS 1
(.000050 MIN. THK.) OVER COPPER PER AMS 2418 (.000010 MIN. THK.)

INSULATOR _____ N/A