

# SPECIFICATION CONTROL DRAWING

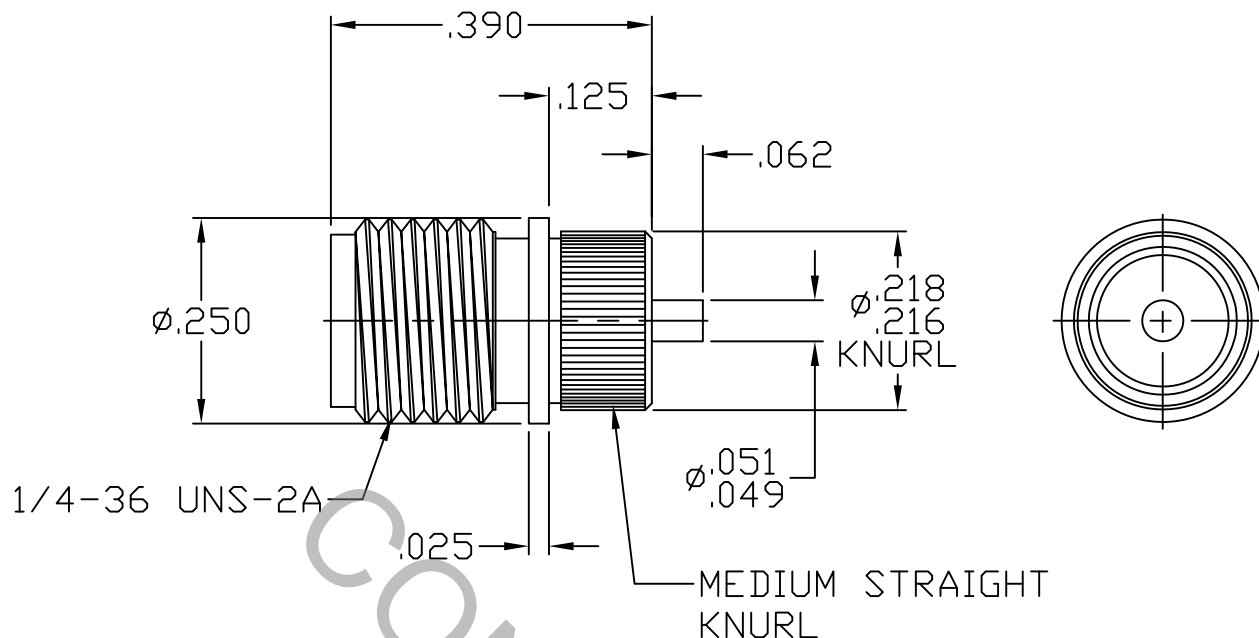

1. MATING INTERFACE DIMENSIONS MIL-STD-348 Fig. 310.2 (SMA JACK).

## 2. ELECTRICAL

FREQUENCY RANGE GHz	DC TO 18.0 GHz
VSWR (MAX) *	1.05 + .005 x FGHz
INSERTION LOSS (dB MAX) *	.060 dB x √FGHz
NOMINAL IMPEDANCE (OHMS)	50
VOLTAGE RATING (MAX. VRMS)	335
RF LEAKAGE (MIN. dB DOWN)	-100 dB - FGHz
TEMPERATURE RATING (DEGREES CENTIGRADE)	-65°C TO + 165°C
DIELECTRIC WITHSTANDING VOLTAGE (MAX. VRMS)	1,000
INSULATION RESISTANCE (MIN. MEGOHMS)	10,000
CONTACT RESISTANCE	
• CENTER CONTACT (MAX. MILLIOHMS)	3.0
• OUTER CONTACT (MAX. MILLIOHMS)	2.0

\* TERMINATED IN A 50 OHM LOAD

**RoHS**  
COMPLIANT

This Document contains proprietary and confidential information.

REV.	DCN NO.	DATE	APP.	DIMENSIONS ARE IN INCHES TOLERANCES			 HAVERHILL, MA 01835
AA	14-2329	10/20/14	TS	DECIMALS	FRACTIONAL	ANGULAR	
				.X ± .030 .XX ± .010 .XXX ± .005	±/64	X ° ± 1 0' X ° X' ± 15'	TITLE SMA, JACK STRAIGHT TERMINAL PRESS MOUNT (MECHANICALLY CAPTURED)
				DRAWN TS	DATE 10/20/14		
				APPROVED DC	DATE 10/20/14		
				CODE IDENT. 2J899	SHEET 1 OF 2	DWG. NO. 9940-0032-6400	

# SPECIFICATION CONTROL DRAWING

## 3. MECHANICAL

### CAPTIVATION-CENTER CONTACT

MAX AXIAL FORCE \_\_\_\_\_ 4.5 LBS.

MAX RADIAL TORQUE \_\_\_\_\_ N/A

### CENTER CONTACT AXIAL FORCES

● INSERTION (MAX. OUNCES) \_\_\_\_\_ INTERFACE 32.0

● WITHDRAWAL (MIN. OUNCES) \_\_\_\_\_ INTERFACE 2.0

CONNECTOR ENGAGEMENT/DISENGAGEMENT (MAX. IN. LBS.) — 2.0

CONNECTOR DURABILITY (MIN. CYCLES) \_\_\_\_\_ 500

RECOMMENDED MATING TORQUE \_\_\_\_\_ 7 - 10 IN. LBS.

## 4. ENVIRONMENTAL

TEMPERATURE CYCLING \_\_\_\_\_ MIL-STD-202, METHOD 102, COND. C ( -65° c TO + 200° c )

SHOCK \_\_\_\_\_ MIL-STD-202, METHOD 213, COND. I (100 G's)

VIBRATION \_\_\_\_\_ MIL-STD-202, METHOD 204, COND. D (20 G's)

MOISTURE RESISTANCE \_\_\_\_\_ MIL-STD-202, METHOD 106, LESS STEP 7b

CORROSION \_\_\_\_\_ MIL-STD-202, METHOD 101, COND. B (48 HOURS)

BAROMETRIC PRESSURE (ALTITUDE) \_\_\_\_\_ MIL-STD-202, METHOD 105, COND. C ( 70,000 FT. ) ( 190 VRMS )

## 5. MATERIAL

BODY \_\_\_\_\_ STAINLESS STEEL PER ASTM A581, TYPE 303, COND. A

CONTACT \_\_\_\_\_ BERYLLIUM COPPER PER ASTM B196/B, 196M-03, COPPER  
ALLOY No. UNS-C17300, TEMPER TD04.

INSULATOR \_\_\_\_\_ TEFLON PER ASTM D 1710-02, TYPE 1, GRADE 1, CLASS B.

## 6. FINISH

BODY \_\_\_\_\_ GOLD PER ASTM B 488, TYPE II, CODE C, CLASS 1.25  
(.000050 MIN. THK.) OVER NICKEL PER SAE AMS QQ-N-290, CLASS 1  
(.000150 MIN. THK.) OVER COPPER PER AMS 2418 (.000010 MIN THK.)

CONTACT \_\_\_\_\_ GOLD PER ASTM B 488, TYPE II, CODE C, CLASS 1.27  
(.000050 MIN. THK.) OVER NICKEL PER SAE AMS QQ-N-290, CLASS 1  
(.000050 MIN. THK.) OVER COPPER PER AMS 2418 (.000010 MIN THK.)

INSULATOR \_\_\_\_\_ N/A