

# SPECIFICATION CONTROL DRAWING

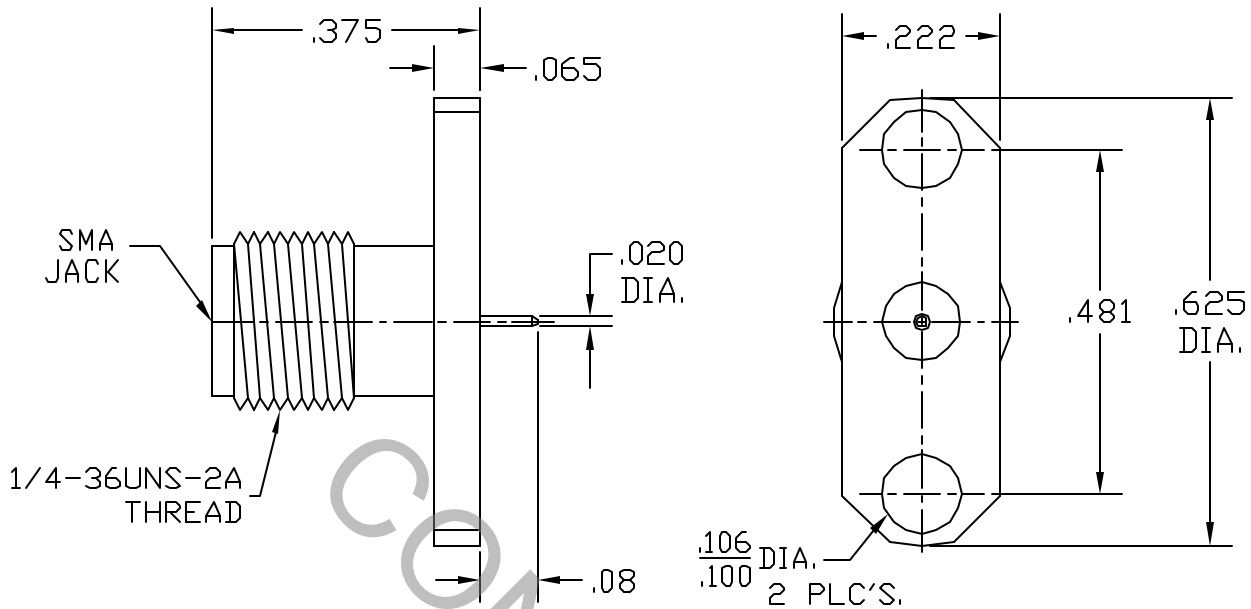

1. MATING INTERFACE DIMENSIONS PER MIL-STD-348A, (Fig. 310.2), SMA, JACK AND DYNAWAVE SPECIFICATION MD-99.

## 2. ELECTRICAL

FREQUENCY RANGE GHz	_____	DC TO 26.5 GHz.
VSWR (MAX.) *	_____	1.06 + .006 x FGHz.
INSERTION LOSS (dB MAX.)	_____	.035 dB $\sqrt{\text{FGHz}}$
NOMINAL IMPEDANCE (OHMS)	_____	50
VOLTAGE RATING (MAX. VRMS)	_____	250
RF LEAKAGE (MIN. dB DOWN)	_____	100 dB - FGHz.
TEMPERATURE RATING (DEGREES CENTIGRADE)	_____	-65° c TO +165° c
DIELECTRIC WITHSTANDING VOLTAGE (MAX. VRMS)	_____	750
INSULATION RESISTANCE (MIN. MEGOHMS)	_____	10,000
CONTACT RESISTANCE		
• CENTER CONTACT (MAX. MILLIOHMS)	_____	6.0
• OUTER CONTACT (MAX. MILLIOHMS)	_____	2.0

\* TERMINATED IN A 50 OHM LOAD

REV.	DCN NO.	DATE	APP.	DIMENSIONS ARE IN INCHES TOLERANCES	 HAVERRILL, MA 01835
AA	02-0844	10/11/02	BN	DECIMALS      FRACTIONAL      ANGULAR X ± .030                              X° ± 1° 0' .XX ± .010                              X°X' ± 15' .XXX ± .005                              ± 1/64	TITLE SMA, JACK 2 HOLE FLANGE .020 DIA. PIN TERMINATION
				DRAWN    SS    DATE 10/11/02 APPROVED    BN    DATE 10/11/02	
				CODE IDENT.      SHEET 1 OF 2      DWG. NO.	
				2J899	9952-0031-6220

# SPECIFICATION CONTROL DRAWING

## 3. MECHANICAL

CAPTIVATION-CENTER CONTACT	
MAX. AXIAL FORCE _____	6.0 LBS.
MAX. RADIAL TORQUE _____	N/A
CENTER CONTACT AXIAL FORCES	
● INSERTION (MAX. OUNCES) _____	48.0
● WITHDRAWAL (MIN. OUNCES) _____	2.0
CONNECTOR ENGAGEMENT/DISENGAGEMENT (MAX. IN. LBS.) _____	2.0
CONNECTOR DURABILITY (MIN. CYCLES) _____	500
RECOMMENDED MATING TORQUE _____	7 - 10 IN. LBS.

## 4. ENVIRONMENTAL

TEMPERATURE CYCLING _____	MIL-STD-202, METHOD 102, COND. C ( -65 200°F +	c )
SHOCK _____	MIL-STD-202, METHOD 213, COND. I (100 G's)	
VIBRATION _____	MIL-STD-202, METHOD 204, COND. D (20 G's)	
MOISTURE RESISTANCE _____	MIL-STD-202, METHOD 108, LESS STEP 7b	
CORROSION _____	MIL-STD-202, METHOD 101, COND. B (48 HOURS)	
BAROMETRIC PRESSURE (ALTITUDE) _____	MIL-STD-202, METHOD 105, COND. C ( 70,000 FT ) (	VRMS )

## 5. MATERIAL

BODY _____	STAINLESS STEEL PER ASTM A 581, TYPE 303, COND. A
CONTACT _____	BERYLLIUM COPPER PER ASTM B196-90, COPPER ALLOY No. UNS-C17300, TEMPER T004.
INSULATOR _____	TEFLON PER ASTM 4894-91.

## 6. FINISH

BODY _____	PASSIVATE PER QQ-P-35A, TYPE I
CONTACT _____	GOLD per MIL-G-45204, TYPE II, GRADE C, CLASS 2 (.000100 Minimum Thickness) OVER NICKEL per QQ-N-290, CLASS 1 (.000100 Minimum Thickness) OVER COPPER per MIL-C-14550 (.000010 Minimum Thickness).
INSULATOR _____	N/A