

SPECIFICATION CONTROL DRAWING

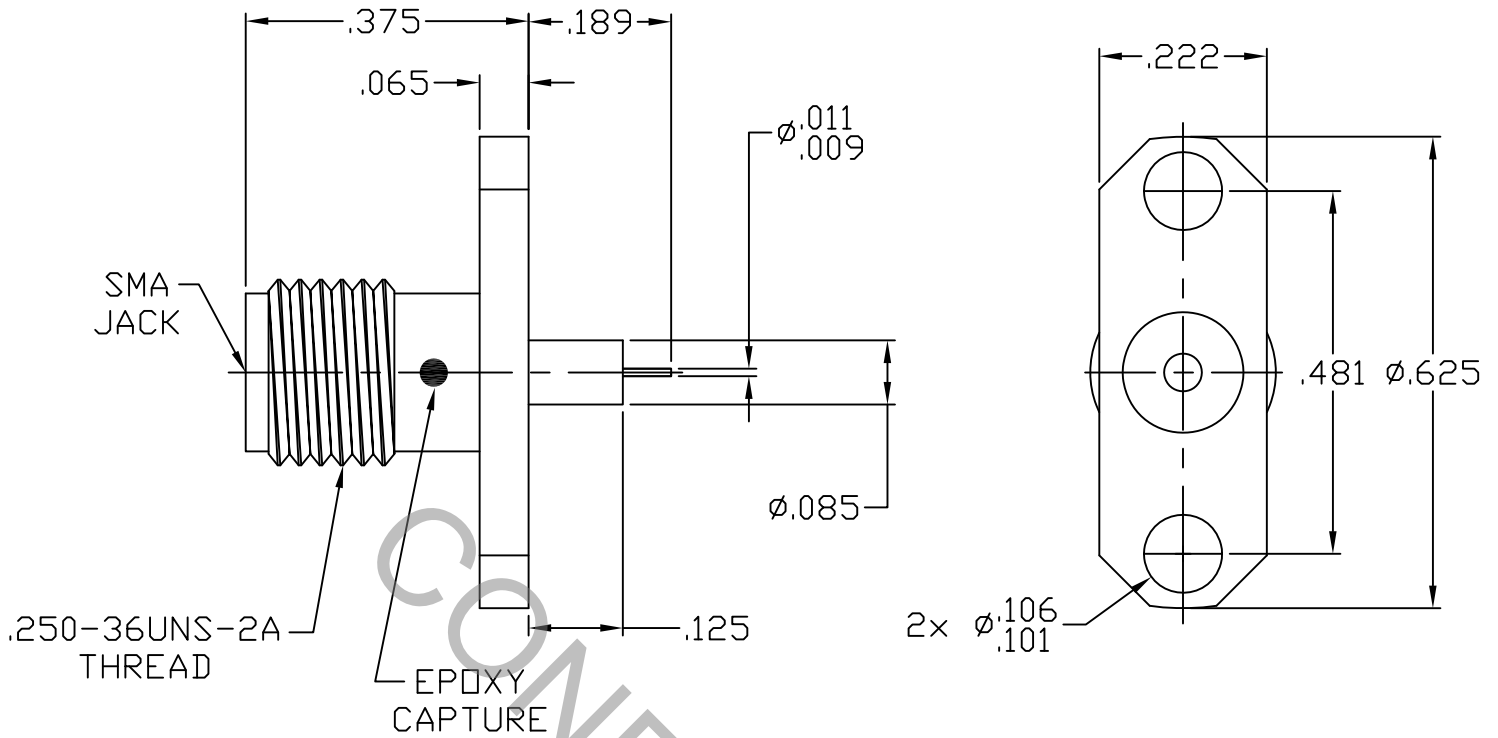

1. MATING INTERFACE DIMENSIONS per MIL-STD-348 Fig. 310.2 (SMA JACK)

2. ELECTRICAL

FREQUENCY RANGE GHz	_____	DC TO 26.5 GHz.
VSWR (MAX) *	_____	1.06 + .006 x FGHz.
INSERTION LOSS (dB MAX) *	_____	.035 dB x $\sqrt{\text{FGHz}}$
NOMINAL IMPEDANCE (OHMS)	_____	50
VOLTAGE RATING (MAX. VRMS)	_____	250
RF LEAKAGE (MIN. dB DOWN)	_____	-90 dB - FGHz.
TEMPERATURE RATING (DEGREES CENTIGRADE)	_____	-65 ° c TO + 165 ° c
DIELECTRIC WITHSTANDING VOLTAGE (MAX. VRMS)	_____	750
INSULATION RESISTANCE (MIN. MEGOHMS)	_____	10,000
CONTACT RESISTANCE		
• CENTER CONTACT (MAX. MILLIOHMS)	_____	6.0
• OUTER CONTACT (MAX. MILLIOHMS)	_____	2.0

* TERMINATED IN A 50 OHM LOAD

RoHS
COMPLIANT

REV.	DCN NO.	DATE	APP.	DIMENSIONS ARE IN INCHES TOLERANCES			 <small>HAVERHILL, MA. 01835</small>
AA	12-1716	8/24/12	TS	DECIMALS	FRACTIONAL	ANGULAR	
				.X ± .030		X ° ± 1' 0"	TITLE SMA JACK, 2 HOLE FLANGE CAPTIVATED CONTACT Ø.010 PIN TERMINAL
				.XX ± .010	± 1/64	X ° X' ± 15"	
				.XXX ± .005			
				DRAWN TS	DATE 8/24/12		
				APPROVED DC	DATE 8/24/12		
				CODE IDENT. 2J899	SHEET 1 OF 2	DWG. NO. 9952-0032-6219	

SPECIFICATION CONTROL DRAWING

3. MECHANICAL

CAPTIVATION-CENTER CONTACT

MAX AXIAL FORCE _____ 6.0 LBS.

MAX RADIAL TORQUE _____ 4.0 IN. OZ.

CENTER CONTACT AXIAL FORCES

● INSERTION (MAX OUNCES) _____ 32.0

● WITHDRAWAL (MIN. OUNCES) _____ 2.0

CONNECTOR ENGAGEMENT/DISENGAGEMENT (MAX LBS.) _____ 2.0

CONNECTOR DURABILITY (MIN. CYCLES) _____ 500

RECOMMENDED MATING TORQUE _____ 7 - 10 IN. LBS.

4. ENVIRONMENTAL

TEMPERATURE CYCLING _____ MIL-STD-202, METHOD 102, COND. C (-65° c TO + 165° c)

SHOCK _____ MIL-STD-202, METHOD 213, COND. I (100 G's)

VIBRATION _____ MIL-STD-202, METHOD 204, COND. D (20 G's)

MOISTURE RESISTANCE _____ MIL-STD-202, METHOD 106, LESS STEP 7b

CORROSION _____ MIL-STD-202, METHOD 101, COND. B (48 HOURS)

BAROMETRIC PRESSURE (ALTITUDE) _____ MIL-STD-202, METHOD 105, COND. C (70,000 FT.) (190 VRMS)

5. MATERIAL

BODY _____ STAINLESS STEEL PER ASTM A 582, TYPE 303, COND. A

CONTACT _____ BERYLLIUM COPPER PER ASTM B196/B, 196M-02, COPPER ALLOY No. UNS C 17300, TEMPER TD04

INSULATOR _____ TEFLON PER ASTM D 1710-02, TYPE 1, GRADE 1, CLASS B.

6. FINISH

BODY _____ PASSIVATE PER AMS 2700, TYPE 2, CLASS 4.

CONTACT _____ GOLD PER ASTM B 488, TYPE I, CODE C, CLASS 1.27
(.000050 Min. THK.) OVER NICKEL PER SAE AMS QQ-N-290, CLASS 1
(.000050 Min. Thk.) OVER COPPER PER AMS 2418 (.000010 MIN. THK.)

INSULATOR _____ N/A