

# SPECIFICATION CONTROL DRAWING

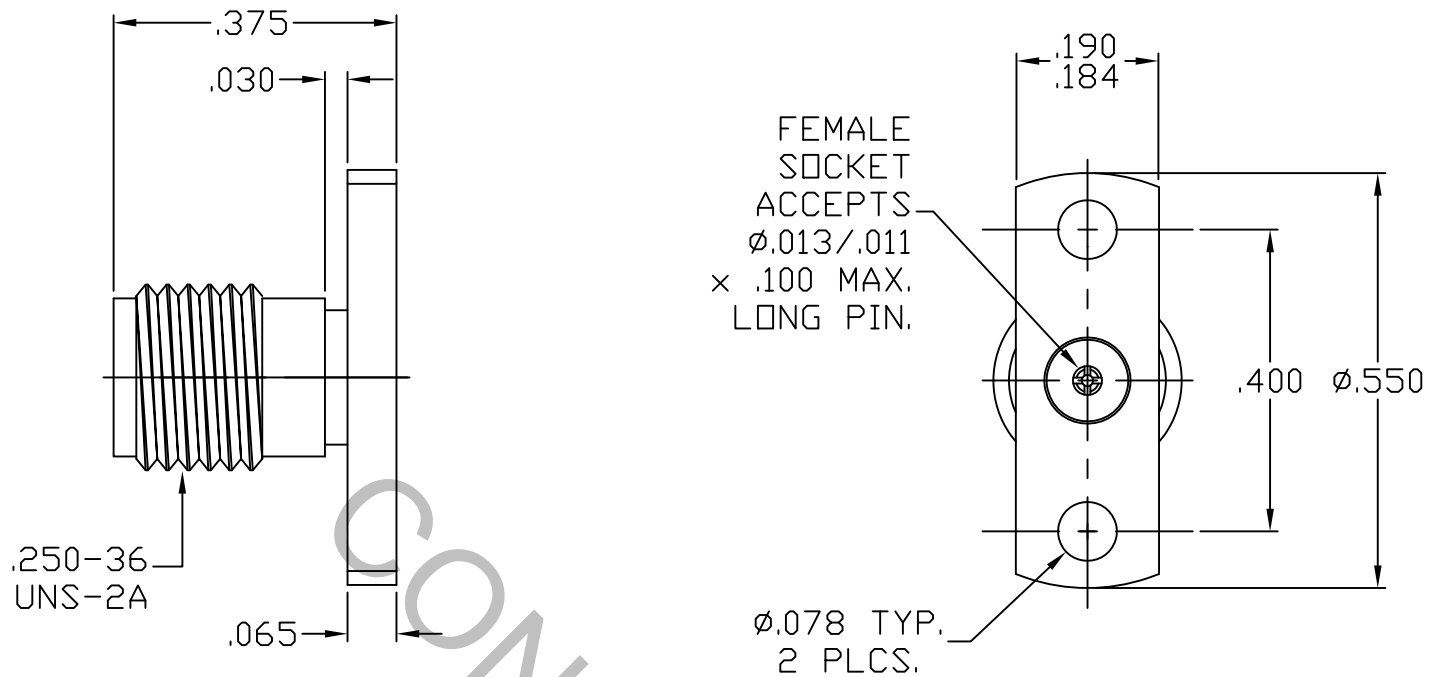

1. MATING INTERFACE DIMENSIONS FOR SMA JACK per MIL-STD-348 (Fig. 310-2).

## 2. ELECTRICAL

FREQUENCY RANGE GHz	_____	DC TO 26.5 GHz
VSWR (MAX.) *	_____	1.05 + .006 x FGHz
INSERTION LOSS (dB MAX.) *	_____	.03 dB x √FGHz
NOMINAL IMPEDANCE (OHMS)	_____	50
VOLTAGE RATING (MAX. VRMS)	_____	250
RF LEAKAGE (MIN. dB DOWN)	_____	100 dB - FGHz
TEMPERATURE RATING (DEGREES CENTIGRADE)	_____	-65 °C TO + 165 °C
DIELECTRIC WITHSTANDING VOLTAGE (MAX. VRMS)	_____	750
INSULATION RESISTANCE (MIN. MEGOHMS)	_____	10,000
CONTACT RESISTANCE		
• CENTER CONTACT (MAX. MILLIOHMS)	_____	6.0
• OUTER CONTACT (MAX. MILLIOHMS)	_____	2.0

\* TERMINATED IN A 50 OHM LOAD

**RoHS**  
COMPLIANT

This Document contains proprietary and confidential information.

REV.	DCN NO.	DATE	APP.	DIMENSIONS ARE IN INCHES TOLERANCES			 HAVERHILL MA. 01835
				DECIMALS	FRACTIONAL	ANGULAR	
AA	18-1033	1/9/18	TS	.X ± .030		X ° ± 1° 0'	TITLE SMA, JACK 2 HOLE FLANGE FIELD REPLACEABLE
AB	18-1042	1/9/18	TS	.XX ± .010 .XXX ± .005	± 1/64	X ° X' ± 15'	
				DRAWN	CDM	DATE	1/9/18
				APPROVED	DGG	DATE	1/9/18
				CODE IDENT.		SHEET	1 OF 2
				2J899		DWG. NO.	9952-0081-6230

# SPECIFICATION CONTROL DRAWING

## 3. MECHANICAL

### CAPTIVATION-CENTER CONTACT

MAX.AXIAL FORCE \_\_\_\_\_ 4.5 LBS.

MAX. RADIAL TORQUE \_\_\_\_\_ N/A

### CENTER CONTACT AXIAL FORCES

● INSERTION (MAX. OUNCES) \_\_\_\_\_ 48.0

● WITHDRAWAL (MIN. OUNCES) \_\_\_\_\_ 2.0

CONNECTOR ENGAGEMENT/DISENGAGEMENT (MAX. IN. LBS.) — 2.0

CONNECTOR DURABILITY (MIN. CYCLES) \_\_\_\_\_ 500

RECOMMENDED MATING TORQUE \_\_\_\_\_ 7 - 10 IN. LBS.

## 4. ENVIRONMENTAL

TEMPERATURE CYCLING \_\_\_\_\_ MIL-STD-202, METHOD 102, COND. C ( -65° c TO + 200°c )

SHOCK \_\_\_\_\_ MIL-STD-202, METHOD 213, COND. I (100 G's)

VIBRATION \_\_\_\_\_ MIL-STD-202, METHOD 204, COND. D (20 G's)

MOISTURE RESISTANCE \_\_\_\_\_ MIL-STD-202, METHOD 106, LESS STEP 7b

CORROSION \_\_\_\_\_ MIL-STD-202, METHOD 101, COND. B (48 HOURS)

BAROMETRIC PRESSURE (ALTITUDE) \_\_\_\_\_ MIL-STD-202, METHOD 105, COND. C ( 70,000 FT. ) ( 190 VRMS )

## 5. MATERIAL

BODY \_\_\_\_\_ STAINLESS STEEL PER ASTM A 581, TYPE 303, COND. A

CONTACT \_\_\_\_\_ BERYLLIUM COPPER PER ASTM B196/B, 196M-03, COPPER ALLOY No. UNS-C17300, TEMPER TD04.

INSULATOR \_\_\_\_\_ TEFLON PER ASTM D 1710-02, TYPE 1 GRADE 1, CLASS B.

## 6. FINISH

BODY \_\_\_\_\_ PASSIVATE PER AMS 2700, TYPE 2, CLASS 4.

CONTACT \_\_\_\_\_ GOLD PER ATSM B 488, TYPE I, CODE C, CLASS 1.25 (.000050 MIN. THK.)  
OVER NICKEL PER SAE AMS QQ-N-290, CLASS 1 (.000050 MIN. THK.)  
OVER COPPER PER AMS 2418, (.000010 MIN. THK.)