

SPECIFICATION CONTROL DRAWING

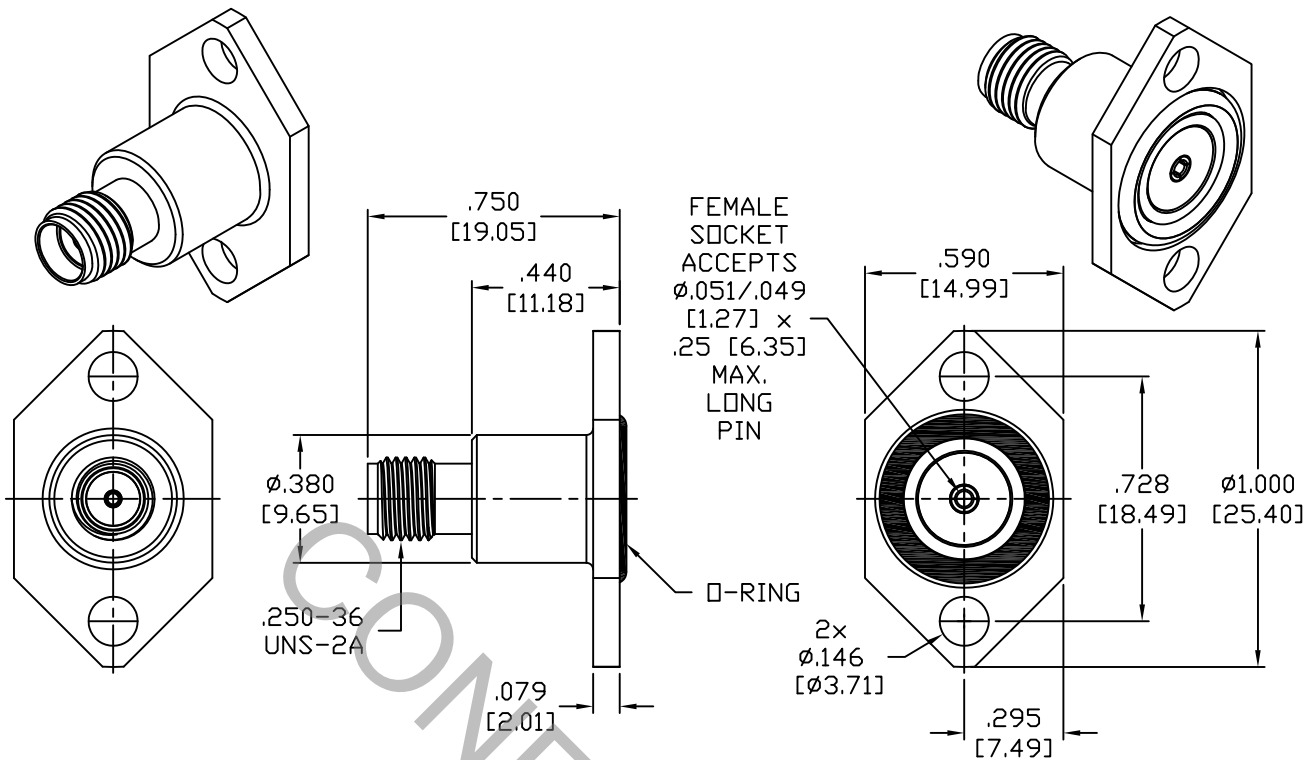

1. MATING INTERFACE DIMENSIONS Per MIL-STD-348, Fig. 310-2 (SMA JACK).

2. ELECTRICAL

FREQUENCY RANGE GHz	_____	DC TO 14.5 GHz
VSWR (MAX.) *	_____	1.10 + .008 x FGHz
INSERTION LOSS (dB MAX.) *	_____	.04 dB x √FGHz
NOMINAL IMPEDANCE (OHMS)	_____	50
VOLTAGE RATING (MAX. VRMS)	_____	410
RF LEAKAGE (MIN. dB DOWN)	_____	-100 dB - FGHz
TEMPERATURE RATING (DEGREES CENTIGRADE)	_____	-65°C TO + 165°C
DIELECTRIC WITHSTANDING VOLTAGE (MAX. VRMS)	_____	1,250
INSULATION RESISTANCE (MIN. MEGOHMS)	_____	5,000
CONTACT RESISTANCE		
• CENTER CONTACT (MAX. MILLIOHMS)	_____	6.0
• OUTER CONTACT (MAX. MILLIOHMS)	_____	2.0

*TERMINATED IN A 50 OHM LOAD

This Document contains proprietary and confidential information.

RoHS
COMPLIANT

REV.	DCN NO.	DATE	APP.	DIMENSIONS ARE IN INCHES TOLERANCES			 HAVERHILL MA. 01835
				DECIMALS	FRACTIONAL	ANGULAR	
AA	13-1731	5/16/13	TS	.x ± .030 .xx ± .010 .xxx ± .005	± 1/64	x ° ± 1'0" x ° x' ± 15'	
AB	13-1747	5/21/13	TS				
AC	13-2030	7/25/13	TS	DRAWN	TS	DATE	5/16/13
AD	13-2527	11/7/13	DC	APPROVED	DC	DATE	5/16/13
				CODE IDENT.	SHEET 1 OF 2		DWG. NO. 9952-0681-6203
				2J899			

TITLE
SMA JACK
2 HOLE FLANGE MOUNT
FIELD REPLACEABLE

SPECIFICATION CONTROL DRAWING

3. MECHANICAL

CAPTIVATION-CENTER CONTACT

MAX.AXIAL FORCE _____ 4.5 LBS.

MAX. RADIAL TORQUE _____ N/A

CENTER CONTACT AXIAL FORCES

● INSERTION (MAX. OUNCES) _____ INTERFACE 32.0 OZ. / REAR 40.0 OZ.

● WITHDRAWAL (MIN. OUNCES) _____ INTERFACE 2.0 OZ. / REAR 1.0 OZ.

CONNECTOR ENGAGEMENT/DISENGAGEMENT (MAX. IN. LBS.) _____ 2.0

CONNECTOR DURABILITY (MIN. CYCLES) _____ 500

RECOMMENDED MATING TORQUE _____ 7 - 10 IN. LBS.

4. ENVIRONMENTAL

TEMPERATURE CYCLING _____ MIL-STD-202, METHOD 102, COND. C (-65°C TO +165°C)

SHOCK _____ MIL-STD-202, METHOD 213, COND. I (100 G's)

VIBRATION _____ MIL-STD-202, METHOD 204, COND. D (20 G's)

MOISTURE RESISTANCE _____ MIL-STD-202, METHOD 106, LESS STEP 7b

CORROSION _____ MIL-STD-202, METHOD 101, COND. B (48 HOURS)

BAROMETRIC PRESSURE (ALTITUDE) _____ MIL-STD-202, METHOD 105, COND. C (70,000 FT.) (310 VRMS)

5. MATERIAL

BODY _____ STAINLESS STEEL PER ASTM-A-582, TYPE 303, COND. A

CONTACT _____ BERYLLIUM COPPER PER ASTM-B-196/B, 196M-03 COPPER ALLOY No. UNS C 17300, TEMPER TD04.

INSULATOR _____ TEFLON PER ASTM-D-1711-02, TYPE 1, GRADE 1, CLASS B.

O'RING _____ SILICONE RUBBER PER ZZ-R-765E, CLASS 1 OR ASM 3304

6. FINISH

BODY _____ PASSIVATE PER AMS 2700, TYPE 2, CLASS 4.

CONTACT _____ GOLD PER ASTM-B-488, TYPE I, CODE C, CLASS 1.27
(.000050 MIN.THK.) OVER NICKEL PER SAE AMS QQ-N-290, CLASS 1
(.000050 MIN. THK.) OVER COPPER PER AMS 2418 (.000010 MIN. THK.)

INSULATOR AND O'RING _____ N/A