

# SPECIFICATION CONTROL DRAWING

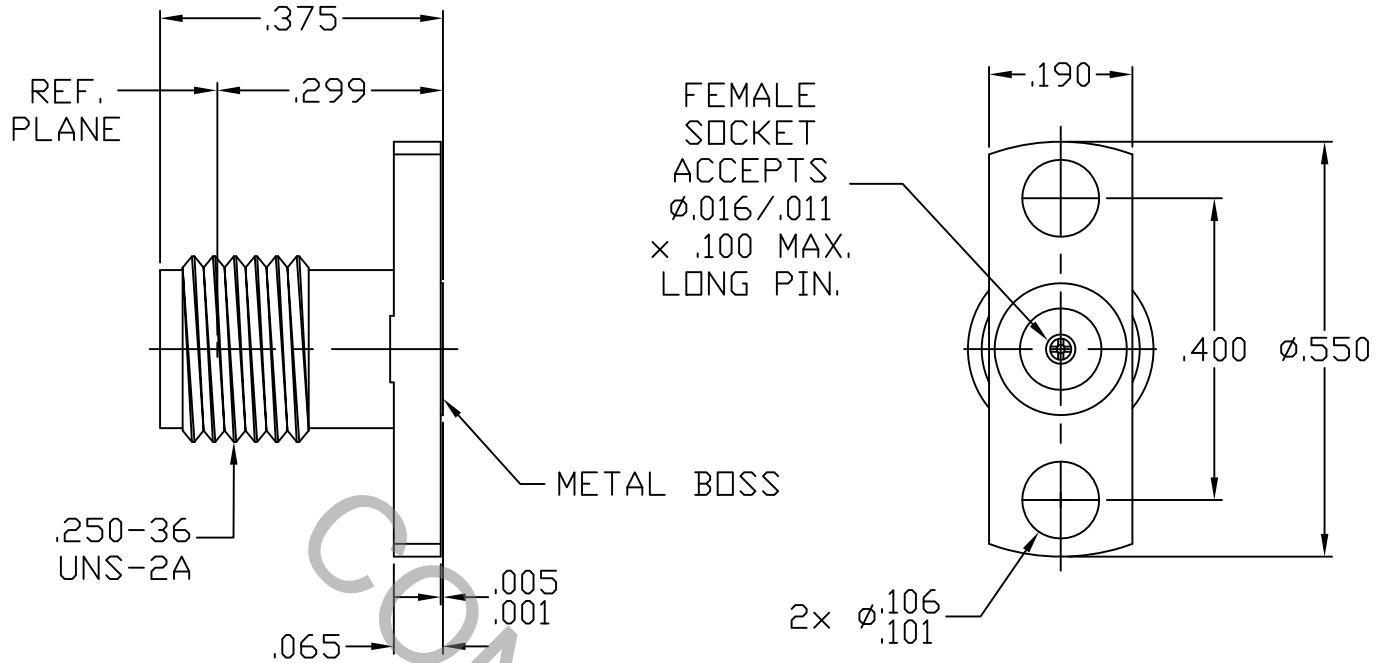

1. MATING INTERFACE DIMENSIONS per MIL-STD-348 Fig. 310-2 (SMA JACK).

## 2. ELECTRICAL

FREQUENCY RANGE GHz	_____	DC TO 26.5 GHz
VSWR (MAX.) *	_____	1.05 + .006 x FGHz
INSERTION LOSS (dB MAX.) *	_____	.03 dB x √FGHz
NOMINAL IMPEDANCE (OHMS)	_____	50
VOLTAGE RATING (MAX. VRMS)	_____	250
RF LEAKAGE (MIN. dB DOWN)	_____	-100 dB - FGHz
TEMPERATURE RATING (DEGREES CENTIGRADE)	_____	-65 °c TO + 165 °c
DIELECTRIC WITHSTANDING VOLTAGE (MAX. VRMS)	_____	750
INSULATION RESISTANCE (MIN. MEGOHMS)	_____	10,000
CONTACT RESISTANCE		
• CENTER CONTACT (MAX. MILLIOHMS)	_____	6.0
• OUTER CONTACT (MAX. MILLIOHMS)	_____	2.0

\*TERMINATED IN A 50 OHM LOAD

**RoHS**  
COMPLIANT

REV.	DCN NO.	DATE	APP.	DIMENSIONS ARE IN INCHES TOLERANCES			 HAVERHILL MA. 01835
AA	10-1173	2/18/10	TS	DECIMALS	FRACTIONAL	ANGULAR	
				.X ± .030		X ° ± 1'0"	TITLE      SMA, JACK 2 HOLE FLANGE FIELD REPLACEABLE WITH METAL BOSS
				.XX ± .010	± 1/64	X ° X' ± 15'	
				.XXX ± .005			
				DRAWN	SS	DATE	2/18/10
				APPROVED	TS	DATE	2/18/10
				CODE IDENT.		SHEET	1 OF 2
				2J899		DWG. NO.	9952-0881-6414

# SPECIFICATION CONTROL DRAWING

## 3. MECHANICAL

### CAPTIVATION-CENTER CONTACT

MAX. AXIAL FORCE \_\_\_\_\_ 4.5 LBS.

MAX. RADIAL TORQUE \_\_\_\_\_ N/A

### CENTER CONTACT AXIAL FORCES

● INSERTION (MAX. OUNCES) \_\_\_\_\_ INTERFACE 48.0 OZ. / FLANGE 32.0 OZ.

● WITHDRAWAL (MIN. OUNCES) \_\_\_\_\_ INTERFACE 2.0 OZ. / FLANGE END 1.0 OZ.

CONNECTOR ENGAGEMENT/DISENGAGEMENT (MAX. LBS.) \_\_\_\_\_ 2.0

CONNECTOR DURABILITY (MIN. CYCLES) \_\_\_\_\_ 500

RECOMMENDED MATING TORQUE \_\_\_\_\_ 7 - 10 IN. LBS.

## 4. ENVIRONMENTAL

TEMPERATURE CYCLING \_\_\_\_\_ MIL-STD-202, METHOD 102, COND. C ( -65 °c TO + 165 °c )

SHOCK \_\_\_\_\_ MIL-STD-202, METHOD 213, COND. I (100 G's)

VIBRATION \_\_\_\_\_ MIL-STD-202, METHOD 204, COND. D (20 G's)

MOISTURE RESISTANCE \_\_\_\_\_ MIL-STD-202, METHOD 106, LESS STEP 7b

CORROSION \_\_\_\_\_ MIL-STD-202, METHOD 101, COND. B (48 HOURS)

BAROMETRIC PRESSURE (ALTITUDE) \_\_\_\_\_ MIL-STD-202, METHOD 105, COND. C ( 70,000 FT. ) ( 310 VRMS )

## 5. MATERIAL

BODY \_\_\_\_\_ STAINLESS STEEL PER ASTM-A-582, TYPE 303, COND. A

CONTACT \_\_\_\_\_ BERYLLIUM COPPER PER ASTM-B-196/B, 197M-03, COPPER ALLOY No. UNS C 17300, TEMPER TD04

INSULATOR \_\_\_\_\_ TEFLON PER ASTM-D-1710-02, TYPE 1, GRADE 1, CLASS B.

## 6. FINISH

BODY \_\_\_\_\_ GOLD PER ASTM B 488, TYPE 1, CODE C, CLASS 1.25 (.000050 MIN. THK.) OVER NICKEL PER QQ-N-290, CLASS 1 (.000150 MIN. THK.) OVER NICKEL (WOODS OR WATTS), (.000010 MIN. THK.)

CONTACT \_\_\_\_\_ GOLD PER ASTM-B-488, TYPE 1, CODE C, CLASS 2.5 (.000100 Min. Thk.) OVER NICKEL per QQ-N-290, CLASS 1 (.000050 Min. Thk.) OVER COPPER PER MIL-C-14550 (.000010 Min. Thk.).

INSULATOR \_\_\_\_\_ N/A