

SPECIFICATION CONTROL DRAWING

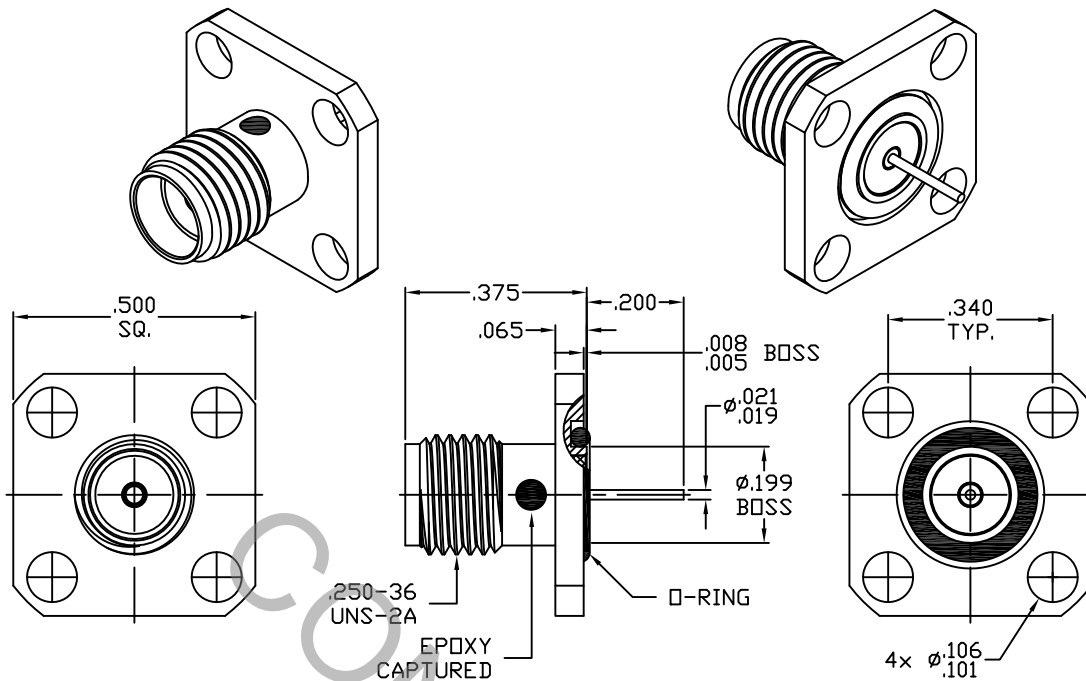

1. MATING INTERFACE DIMENSIONS PER MIL-STD-348, Fig. 310.2 (SMA JACK).

2. ELECTRICAL

FREQUENCY RANGE GHz	_____	DC TO 18.0 GHz.
VSWR (MAX.) *	_____	1.06 + .015 x FGHz.
INSERTION LOSS (dB MAX.)	_____	.035 dB x $\sqrt{\text{FGHz}}$
NOMINAL IMPEDANCE (OHMS)	_____	50
VOLTAGE RATING (MAX. VRMS)	_____	250
RF LEAKAGE (MIN. dB DOWN)	_____	-80 dB - FGHz.
TEMPERATURE RATING (DEGREES CENTIGRADE)	_____	-65°C TO + 165°C
DIELECTRIC WITHSTANDING VOLTAGE (MAX. VRMS)	_____	750
INSULATION RESISTANCE (MIN. MEGOHMS)	_____	5,000
CONTACT RESISTANCE		
• CENTER CONTACT (MAX. MILLIOHMS)	_____	6.0
• OUTER CONTACT (MAX. MILLIOHMS)	_____	2.0

* TERMINATED IN A 50 OHM LOAD

RoHS
COMPLIANT

This Document contains proprietary and confidential information.

REV.	DCN NO.	DATE	APP.	DIMENSIONS ARE IN INCHES TOLERANCES			HAVERHILL, MA 01835
				DECIMALS	FRACTIONAL	ANGULAR	
AA	13-2056	7/29/13	TS	.X ± .030 .XX ± .010 .XXX ± .005	± 1/64	X° ± 1°0' X°X' ± 15'	
AB	13-2065	7/30/13	DC				
BA	14-2025	8/19/14	TS	DRAWN TS	DATE 7/29/13	TITLE SMA JACK, 4 HOLE FLANGE, STRAIGHT PIN TERMINAL	
CA	14-2323	10/16/14	DC	APPROVED DC	DATE 7/29/13		
				CODE IDENT. 2J899	SHEET 1 OF 2	DWG. NO. 9954-0632-6206	

SPECIFICATION CONTROL DRAWING

3. MECHANICAL

CAPTIVATION-CENTER CONTACT

MAX.AXIAL FORCE _____ 6.0 LBS.

MAX. RADIAL TORQUE _____ 4.0 IN. OZ.

CENTER CONTACT AXIAL FORCES

● INSERTION (MAX. OUNCES) _____ 32.0

● WITHDRAWAL (MIN. OUNCES) _____ 2.0

CONNECTOR ENGAGEMENT/DISENGAGEMENT (MAX. IN. LBS.) _____ 2.0

CONNECTOR DURABILITY (MIN. CYCLES) _____ 500

RECOMMENDED MATING TORQUE _____ 7 - 10 IN. LBS.

4. ENVIRONMENTAL

TEMPERATURE CYCLING _____ MIL-STD-202, METHOD 102, COND. C (-65°C TO + 165°C)

SHOCK _____ MIL-STD-202, METHOD 213, COND. I (100 G's)

VIBRATION _____ MIL-STD-202, METHOD 204, COND. D (20 G's)

MOISTURE RESISTANCE _____ MIL-STD-202, METHOD 106, LESS STEP 7b

CORROSION _____ MIL-STD-202, METHOD 101, COND. B (48 HOURS)

BAROMETRIC PRESSURE (ALTITUDE) _____ MIL-STD-202, METHOD 105, COND. C (70,000 FT.) (190 VRMS)

5. MATERIAL

BODY _____ STAINLESS STEEL PER ASTM-A-582, TYPE 303, COND. A

CONTACT _____ BERYLLIUM COPPER PER ASTM B196/B, 196M-03, COPPER ALLOY No. UNS-C17300, TEMPER TD04.

INSULATOR _____ TEFLON PER ASTM-D-1710-02, TYPE 1, GRADE 1, CLASS B.

O'RING _____ SILICONE RUBBER PER ZZ-R-765E, CLASS 1 OR ASM 3304.

6. FINISH

BODY _____ PASSIVATE PER AMS-2700, TYPE 2, CLASS 4

CONTACT _____ GOLD PER ASTM-B-488, TYPE I, CODE C, CLASS 1.25
(.000050 MIN. THK.) OVER NICKEL PER SAE-AMS-QQ-N-290
CLASS 1 (.000050 MIN. THK.) OVER COPPER PER AMS-2418
(.000010 MIN. THK.)

INSULATOR AND O'RING _____ N/A