

SPECIFICATION CONTROL DRAWING

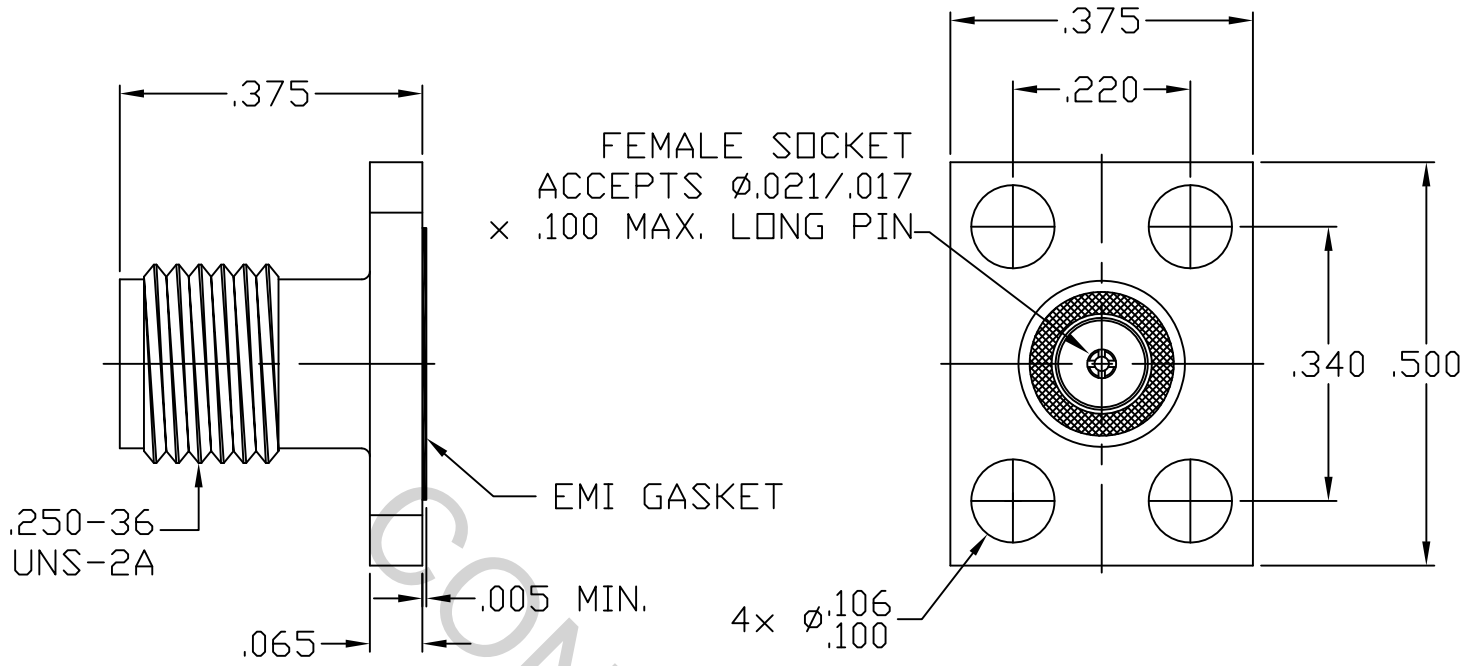

1. MATING INTERFACE DIMENSIONS Per MIL-STD-348, Fig. 310-2 (SMA JACK).

2. ELECTRICAL

FREQUENCY RANGE GHz	_____	DC TO 26.5 GHz
VSWR (MAX.) *	_____	$1.05 + .006 \times \text{FGHz}$
INSERTION LOSS (dB MAX.) *	_____	$.03 \text{ dB} \times \sqrt{\text{FGHz}}$
NOMINAL IMPEDANCE (OHMS)	_____	50
VOLTAGE RATING (MAX. VRMS)	_____	250
RF LEAKAGE (MIN. dB DOWN)	_____	$100 \text{ dB} - \text{FGHz}$
TEMPERATURE RATING (DEGREES CENTIGRADE)	_____	$-65^\circ \text{C TO } +165^\circ \text{C}$
DIELECTRIC WITHSTANDING VOLTAGE (MAX. VRMS)	_____	750
INSULATION RESISTANCE (MIN. MEGOHMS)	_____	5,000
CONTACT RESISTANCE		
• CENTER CONTACT (MAX. MILLIOHMS)	_____	6.0
• OUTER CONTACT (MAX. MILLIOHMS)	_____	2.0

*TERMINATED IN A 50 OHM LOAD

This Document contains proprietary and confidential information.

RoHS
COMPLIANT

REV.	DCN NO.	DATE	APP.	DIMENSIONS ARE IN INCHES TOLERANCES				 HAVERHILL MA. 01835	
-	525	3/88	DGG	DECIMALS	FRACTIONAL	ANGULAR			
				$.x \pm .030$		$x^\circ \pm 1'0''$			
				$.xx \pm .010$	$\pm 1/64$	$x^\circ x' \pm 15''$			
				$.xxx \pm .005$					
AA	08-1337	3/26/08	DC	DRAWN	RF	DATE	3/88	TITLE SMA JACK 4 HOLE FLANGE MOUNT FIELD REPLACEABLE	
AB	18-1499	5/7/18	DC						
				APPROVED	DGG	DATE	3/88		
				CODE IDENT.			SHEET 1 OF 2	DWG. NO.	9954-0781-6229
				2J899					

SPECIFICATION CONTROL DRAWING

3. MECHANICAL

CAPTIVATION-CENTER CONTACT

MAX.AXIAL FORCE _____ 6.0 LBS.

MAX. RADIAL TORQUE _____ N/A

CENTER CONTACT AXIAL FORCES

● INSERTION (MAX. OUNCES) _____ INTERFACE 48.0 OZ. / REAR 32.0 OZ.

● WITHDRAWAL (MIN. OUNCES) _____ INTERFACE 2.0 OZ. / REAR 1.0 OZ.

CONNECTOR ENGAGEMENT/DISENGAGEMENT (MAX. IN. LBS.) _____ 2.0

CONNECTOR DURABILITY (MIN. CYCLES) _____ 500

RECOMMENDED MATING TORQUE _____ 7 - 10 IN. LBS.

4. ENVIRONMENTAL

TEMPERATURE CYCLING _____ MIL-STD-202, METHOD 102, COND. C (-65 °c TO + 200°c)

SHOCK _____ MIL-STD-202, METHOD 213, COND. I (100 G's)

VIBRATION _____ MIL-STD-202, METHOD 204, COND. D (20 G's)

MOISTURE RESISTANCE _____ MIL-STD-202, METHOD 106, LESS STEP 7b

CORROSION _____ MIL-STD-202, METHOD 101, COND. B (48 HOURS)

BAROMETRIC PRESSURE (ALTITUDE) _____ MIL-STD-202, METHOD 105, COND. C (70,000 FT.) (190 VRMS)

5. MATERIAL

BODY _____ STAINLESS STEEL PER ASTM-A-582, TYPE 303, COND. A

CONTACT _____ BERYLLIUM COPPER PER ASTM-B-196, COPPER ALLOY
UNS C 17300, TEMPER HT

INSULATOR _____ TEFLON PER ASTM-D-1710

EMI GASKET _____ SILVER PLATED ALUMINUM IN SILICONE

6. FINISH

BODY _____ PASSIVATE PER AMS-2700, TYPE 2, CLASS 4.

CONTACT _____ GOLD PER ASTM-B-488, TYPE I, CODE C, CLASS 1.27
(.000050 MIN. THK.) OVER NICKEL per QQ-N-290,
(.000050 MIN. THK.) OVER COPPER per AMS-2418,
(.000010 MIN. THK.).

INSULATOR & EMI GASKET _____ N/A