

SPECIFICATION CONTROL DRAWING

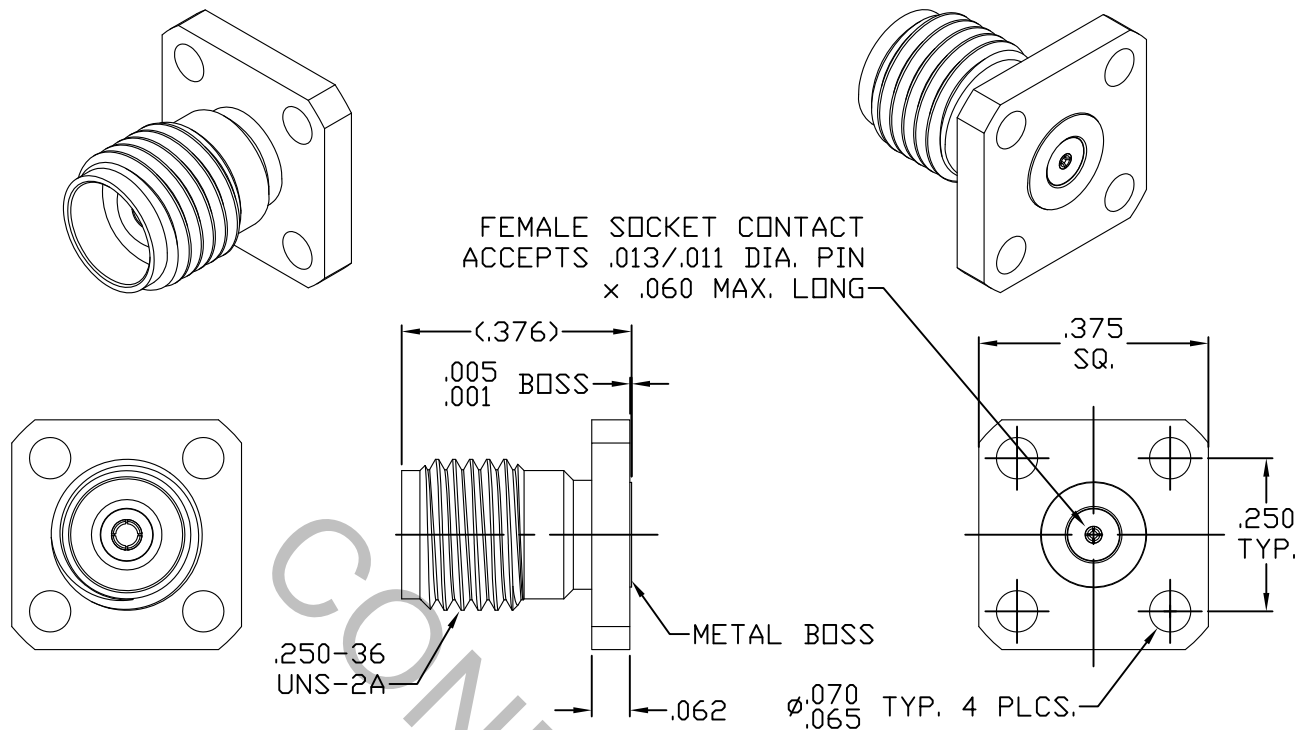

1. MATING INTERFACE DIMENSIONS PER DYNAWAVE MD-99-46 (SMA, JACK, 46.0 GHz.).

2. ELECTRICAL

FREQUENCY RANGE GHz	DC TO 46.0 GHz
VSWR (MAX.) *	1.05 + .006 x FGHz
INSERTION LOSS (dB MAX.) *	.035 dB x √FGHz
NOMINAL IMPEDANCE (OHMS)	50
VOLTAGE RATING (MAX. VRMS)	250
RF LEAKAGE (MIN. dB DOWN)	100 dB - FGHz
TEMPERATURE RATING (DEGREES CENTIGRADE)	-65°C TO + 165°C
DIELECTRIC WITHSTANDING VOLTAGE (MAX. VRMS)	750
INSULATION RESISTANCE (MIN. MEGOHMS)	5,000
CONTACT RESISTANCE	
• CENTER CONTACT (MAX. MILLIOHMS)	6.0
• OUTER CONTACT (MAX. MILLIOHMS)	2.0

* TERMINATED IN A 50 OHM LOAD

This Document contains proprietary and confidential information.

RoHS
COMPLIANT

REV.	DCN NO.	DATE	APP.	DIMENSIONS ARE IN INCHES TOLERANCES			 HAVERHILL, MA 01835
AA	10-1909	9/27/10	TS	DECIMALS	FRACTIONAL	ANGULAR	
BA	16-2261	10/12/16	DC	.X ± .030 .XX ± .010 .XXX ± .005	±/64	X ° ± 1 ° X ° X' ± 15'	
				DRAWN TS	DATE 9/27/10	TITLE SMA, JACK 4 HOLE FLANGE TAB TERMINAL	
				APPROVED DC	DATE 9/27/10		
				CODE IDENT. 2J899	SHEET 1 OF 2		

SPECIFICATION CONTROL DRAWING

3. MECHANICAL

CAPTIVATION-CENTER CONTACT

MAX AXIAL FORCE _____ 4.5 LBS.

MAX RADIAL TORQUE _____ N/A

CENTER CONTACT AXIAL FORCES

● INSERTION (MAX OUNCES) _____ INTERFACE 32.0

● WITHDRAWAL (MIN. OUNCES) _____ INTERFACE 2.0

CONNECTOR ENGAGEMENT/DISENGAGEMENT (MAX IN. LBS.) — 2.0

CONNECTOR DURABILITY (MIN. CYCLES) _____ 500

RECOMMENDED MATING TORQUE _____ 7 - 10 IN. LBS.

4. ENVIRONMENTAL

TEMPERATURE CYCLING _____ MIL-STD-202, METHOD 102, COND. C (-65° c TO + 165° c)

SHOCK _____ MIL-STD-202, METHOD 213, COND. I (100 G's)

VIBRATION _____ MIL-STD-202, METHOD 204, COND. D (20 G's)

MOISTURE RESISTANCE _____ MIL-STD-202, METHOD 106, LESS STEP 7b

CORROSION _____ MIL-STD-202, METHOD 101, COND. B (48 HOURS)

BAROMETRIC PRESSURE (ALTITUDE) — MIL-STD-202, METHOD 105, COND. C (70,000 FT.) (190 VRMS)

5. MATERIAL

BODY & PRESS SLEEVE _____ STAINLESS STEEL PER ASTM A 582, TYPE 303, COND. A

CONTACT _____ BERYLLIUM COPPER PER ASTM B196/B, 196M-03, COPPER ALLOY No. UNS-C17300, TEMPER TD04.

INSULATOR _____ TEFLON PER ASTM D 1710-02, TYPE 1, GRADE 1, CLASS B.

6. FINISH

BODY _____ PASSIVATE PER AMS 2700, TYPE 2, CLASS 4.

PRESS SLEEVE _____ GOLD PER ASTM B 488, TYPE 1, CODE C, CLASS 1.27
(.000050 MIN. THK.) OVER NICKEL PER SAE AMS QQ-N-290,
CLASS 1 (.000050 MIN. THK.) OVER COPPER PER AMS 2418,
(.000040 MIN. THK.) OVER NICKEL (WOODS OR WATTS)
(.000010 MIN. THK.)

CONTACT _____ GOLD PER ASTM B 488, TYPE 1, CODE C, CLASS 1.27
(.000050 MIN. THK.) OVER NICKEL PER SAE AMS QQ-N-290,
CLASS 1 (.000050 MIN. THK.) OVER COPPER PER AMS 2418,
(.000010 MIN. THK.)

INSULATOR _____ N/A