

SPECIFICATION CONTROL DRAWING

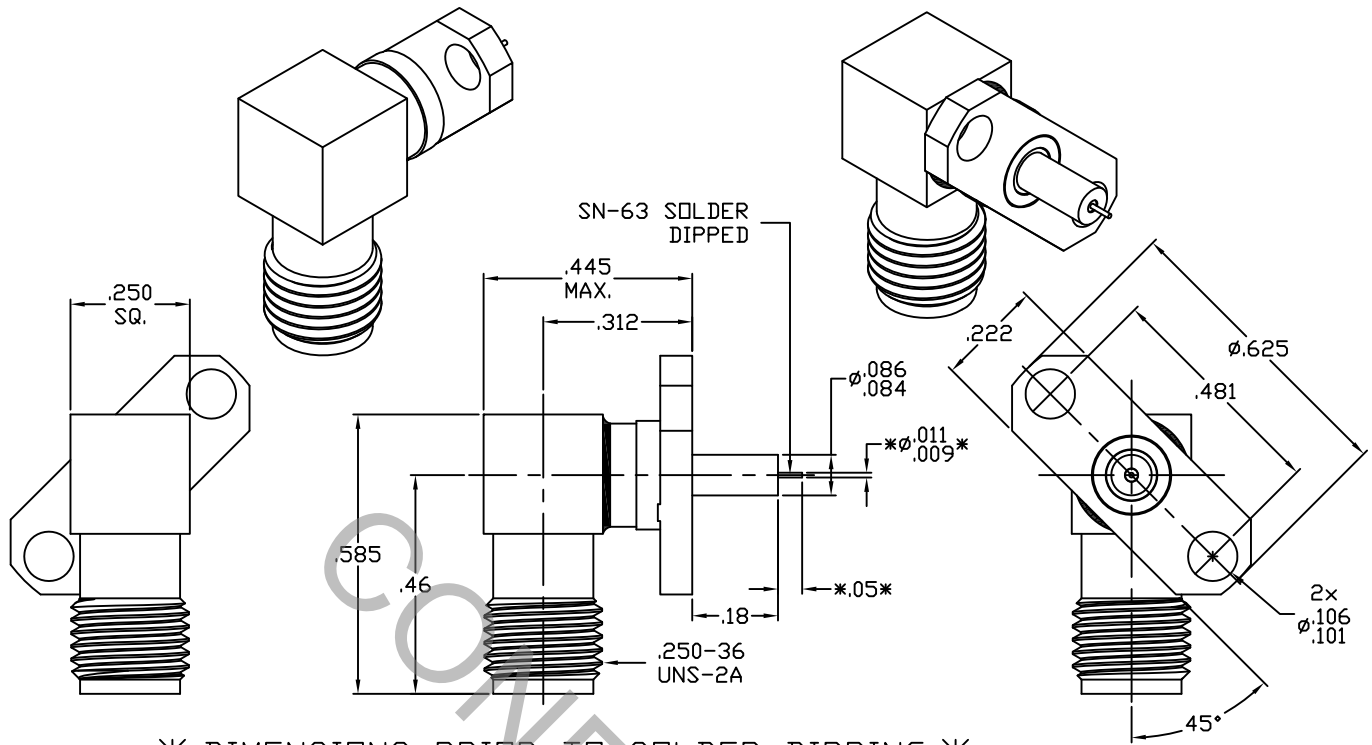

* DIMENSIONS PRIOR TO SOLDER DIPPING *

1. MATING INTERFACE DIMENSIONS Per MIL-STD-348 Fig. 310-2 (SMA JACK).

2. ELECTRICAL

FREQUENCY RANGE GHz	_____	DC TO 22.0 GHz.
VSWR (MAX) *	_____	1.07 + .010 x FGHz.
INSERTION LOSS (dB MAX) *	_____	.05 dB x √FGHz.
NOMINAL IMPEDANCE (OHMS)	_____	50
VOLTAGE RATING (MAX. VRMS)	_____	250
RF LEAKAGE (MIN. dB DOWN)	_____	-100 dB - FGHz.
TEMPERATURE RATING (DEGREES CENTIGRADE)	_____	-65 ° c TO +165 ° c
DIELECTRIC WITHSTANDING VOLTAGE (MAX. VRMS)	_____	750
INSULATION RESISTANCE (MIN. MEGOHMS)	_____	5,000
CONTACT RESISTANCE		
• CENTER CONTACT (MAX. MILLIOHMS)	_____	6.0
• OUTER CONTACT (MAX. MILLIOHMS)	_____	2.0

* TERMINATED IN A 50 OHM LOAD

RoHS
COMPLIANT

This Document contains proprietary and confidential information.

REV.	DCN NO.	DATE	APP.	DIMENSIONS ARE IN INCHES TOLERANCES			 HAVERHILL, MA. 01835
AA	13-2074	7/31/13	DC	DECIMALS .X ± .030 .XX ± .010 .XXX ± .005	FRACTIONAL ± 1/64	ANGULAR X ° ± 1'0" X ° X' ± 15"	
AB	13-2102	8/6/13	DC	SURFACE ROUGHNESS 63 √MIL-STD 10.			
				DRAWN DC	DATE 7/31/13	TITLE SMA JACK, RIGHT ANGLE, 2 HOLE FLANGE, 0.010 PIN TERMINAL	
				APPROVED DC	DATE 7/31/13		
				CODE IDENT. 2J899	SHEET 1 OF 2		
						DWG. NO. 9956-1031-6241	

SPECIFICATION CONTROL DRAWING

3. MECHANICAL

CAPTIVATION-CENTER CONTACT

- MAX AXIAL FORCE _____ 6.0 LBS.
- MAX RADIAL TORQUE _____ 4.0 IN./OZ.

CENTER CONTACT AXIAL FORCES

- INSERTION (MAX OUNCES) _____ 40.0 MAX
- WITHDRAWAL (MIN. OUNCES) _____ 2.0 MIN.

CONNECTOR ENGAGEMENT/DISENGAGEMENT (MAX IN. LBS) — 2.0

CONNECTOR DURABILITY (MIN. CYCLES) _____ 500

RECOMMENDED MATING TORQUE _____ 7 - 10 IN. LBS.

4. ENVIRONMENTAL

TEMPERATURE CYCLING _____ MIL-STD-202, METHOD 102, COND. C (-65 ° c TO + 165 ° c)

SHOCK _____ MIL-STD-202, METHOD 213, COND. I (100 G's)

VIBRATION _____ MIL-STD-202, METHOD 204, COND. D (20 G's)

MOISTURE RESISTANCE _____ MIL-STD-202, METHOD 106, LESS STEP 7b

CORROSION _____ MIL-STD-202, METHOD 101, COND. B (48 HOURS)

BAROMETRIC PRESSURE (ALTITUDE) _____ MIL-STD-202, METHOD 105, COND. C (70,000 FT.) (190 VRMS)

5. MATERIAL

CONNECTOR BODY _____ STAINLESS STEEL PER ASTM-A-582, TYPE 303, COND. A

CENTER CONTACTS _____ BERYLLIUM COPPER PER ASTM B196/B, 196M-03, COPPER ALLOY No. UNS C17300, TEMPER TD04.

INSULATORS _____ TEFLON PER ASTM-D-1710-02, TYPE 1, GRADE 1, CLASS B.

6. FINISH

CONNECTOR BODY _____ PASSIVATE PER AMS-2700, TYPE 2, CLASS 4

CENTER CONTACTS _____ GOLD PER ASTM B 488, TYPE 1, CODE C, CLASS 1.27 (.000050 MIN. THK.) OVER NICKEL PER SAE-AMS-QQ-N-290, CLASS 1, (.000050 MIN. THK.) OVER COPPER PER AMS-2418 (.000010 MIN. THK.).

INSULATORS _____ N/A