

SPECIFICATION CONTROL DRAWING

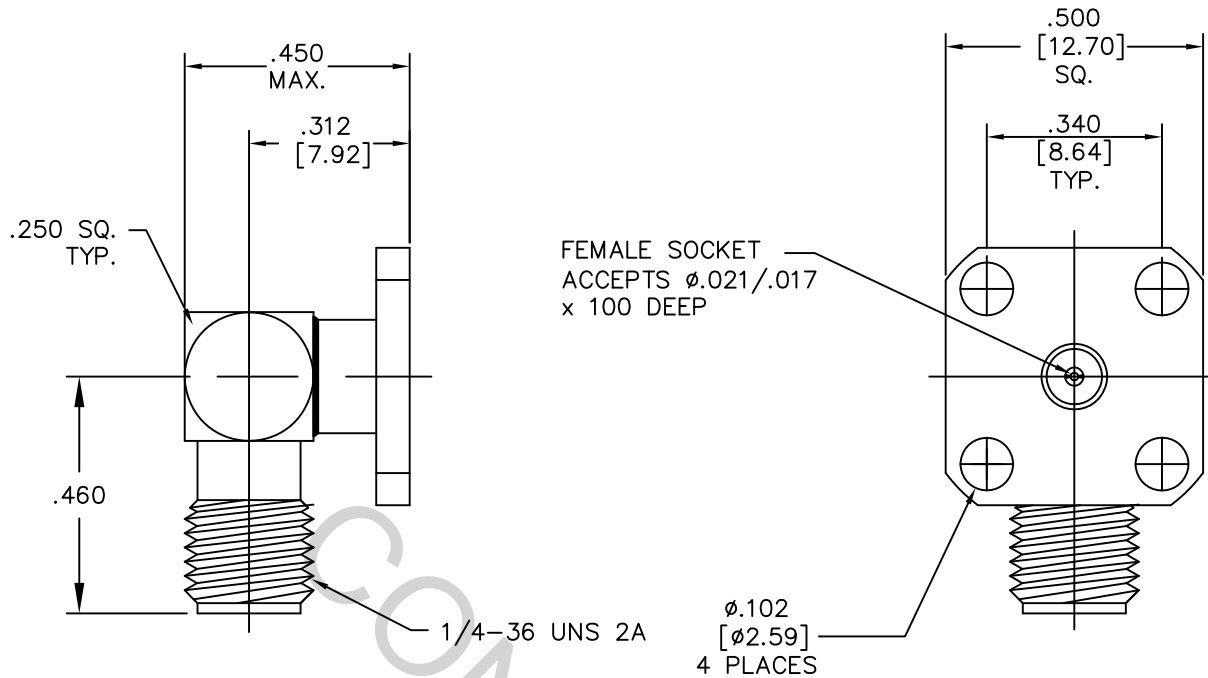

1. MATING INTERFACE DIMENSIONS FOR SMA JACK per MIL-STD-348 (Fig. 310-2).

2. ELECTRICAL

FREQUENCY RANGE GHz	_____	DC TO 22.0 GHz.
VSWR (MAX.) *	_____	1.07 + .010 x FGHz
INSERTION LOSS (dB MAX.) *	_____	.04 dB x $\sqrt{\text{FGHz}}$
NOMINAL IMPEDANCE (OHMS)	_____	50
VOLTAGE RATING (MAX. VRMS)	_____	250
RF LEAKAGE (MIN. dB DOWN)	_____	100 dB - FGHz
TEMPERATURE RATING (DEGREES CENTIGRADE)	_____	-65°c TO + 165 °c
DIELECTRIC WITHSTANDING VOLTAGE (MAX. VRMS)	_____	750
INSULATION RESISTANCE (MIN. MEGOHMS)	_____	10,000
CONTACT RESISTANCE		
• CENTER CONTACT (MAX. MILLIOHMS)	_____	6.0
• OUTER CONTACT (MAX. MILLIOHMS)	_____	2.0

* TERMINATED IN A 50 OHM LOAD

This Document contains proprietary and confidential information.

RoHS
COMPLIANT

REV.	DCN NO.	DATE	APP.	DIMENSIONS ARE IN INCHES TOLERANCES				 HAVERHILL, MA 03185	
				DECIMALS	FRACTIONAL	ANGULAR			
-	321	5/87	DGG	.X ± .030 .XX ± .010 .XXX ± .005	± 1/64	X ° ± 1 0' X ° X' ± 15'			
A	610	11/88	DGG						
AA	18-1652	6/8/18	DC	DRAWN	CDM	DATE	5/87	TITLE SMA, JACK 4 HOLE FLANGE RIGHT ANGLE FIELD REPLACEABLE	
				APPROVED	DGG	DATE	5/87		
				CODE IDENT.		SHEET 1 OF 2			
				2J899				DWG. NO.	9958-0081-6220

SPECIFICATION CONTROL DRAWING

3. MECHANICAL

CAPTIVATION-CENTER CONTACT
MAX.AXIAL FORCE _____ 6.0 LBS.
MAX. RADIAL TORQUE _____ 4.0 IN. OZ.
CENTER CONTACT AXIAL FORCES
● INSERTION (MAX. OUNCES) _____ 48.0
● WITHDRAWAL (MIN. OUNCES) _____ 2.0
CONNECTOR ENGAGEMENT/DISENGAGEMENT (MAX. IN. LBS.) _____ 2.0
CONNECTOR DURABILITY (MIN. CYCLES) _____ 500
RECOMMENDED MATING TORQUE _____ 7 - 10 INCH LBS.

4. ENVIRONMENTAL

TEMPERATURE CYCLING _____ MIL-STD-202, METHOD 102, COND. C (-65 °c TO + 200 c°)
SHOCK _____ MIL-STD-202, METHOD 213, COND. I (100 G's)
VIBRATION _____ MIL-STD-202, METHOD 204, COND. D (20 G's)
MOISTURE RESISTANCE _____ MIL-STD-202, METHOD 106, LESS STEP 7b
CORROSION _____ MIL-STD-202, METHOD 101, COND. B (48 HOURS)
BAROMETRIC PRESSURE (ALTITUDE) _____ MIL-STD-202, METHOD 105, COND. C (70,000 FT.) (190 VRMS)

5. MATERIAL

BODY _____ STAINLESS STEEL PER ASTM-A-582, TYPE 303, COND. A
CONTACT AND NAIL HEAD CONTACT _____ BERYLLIUM COPPER PER ASTM-B-196/B, 196M-03, COPPER ALLOY No. UNS-C17300, TEMPER TD04.
INSULATOR _____ TEFLON PER ASTM-D-1710-02, TYPE 1, GRADE 1, CLASS B.

6. FINISH

BODY _____ PASSIVATE PER AMS-2700, TYPE 2, CLASS 4
CONTACT AND NAIL HEAD CONTACT _____ GOLD PER ASTM-B-488, TYPE II, CODE C, CLASS 1.27
(.000050 MIN. THK.) OVER NICKEL PER SAE-AMS-QQ-N-290
CLASS 1 (.000050 MIN. THK.) OVER COPPER PER AMS-2418
(.000010 MIN. THK.)
INSULATOR _____ N/A