

# SPECIFICATION CONTROL DRAWING

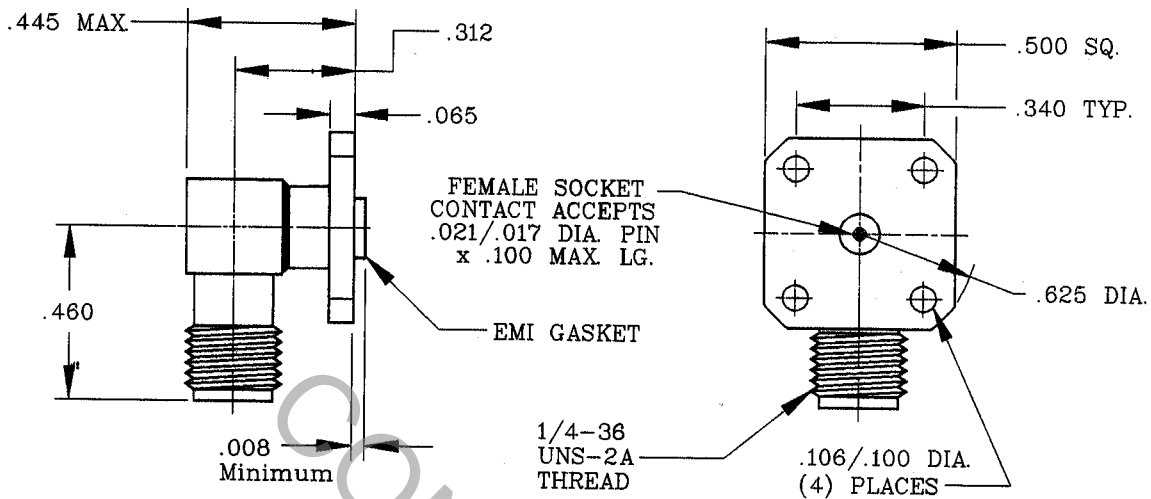

1. MATING INTERFACE DIMENSIONS FOR SMA JACK per MIL-STD-348 (Fig. 310-2).

## 2. ELECTRICAL

FREQUENCY RANGE GHz	_____	DC TO 22.0 GHz
VSWR (MAX.) *	_____	1.07 + .010 x FGHz
INSERTION LOSS (dB MAX.) *	_____	.04 dB x $\sqrt{\text{FGHz}}$
NOMINAL IMPEDANCE (OHMS)	_____	50
VOLTAGE RATING (MAX. VRMS)	_____	250
RF LEAKAGE (MIN. dB DOWN)	_____	100 dB - FGHz
TEMPERATURE RATING (DEGREES CENTIGRADE)	_____	-65°c TO + 165°c
DIELECTRIC WITHSTANDING VOLTAGE (MAX. VRMS)	_____	750
INSULATION RESISTANCE (MIN. MEGOHMS)	_____	10,000
CONTACT RESISTANCE		
• CENTER CONTACT (MAX. MILLIOHMS)	_____	6.0
• OUTER CONTACT (MAX. MILLIOHMS)	_____	2.0

\* TERMINATED IN A 50 OHM LOAD

REV.	DCN NO.	DATE.	APP.	DIMENSIONS ARE IN INCHES TOLERANCES			GEORGETOWN MA. 01833
				DECIMALS	FRACTIONAL	ANGULAR	
—	321	5/87	DGG	X ± .030		X° ± 1°0'	
A	610	11/88	DGG	.XX ± .010	± 1/64	X° X' ± 15'	
				.XXX ± .005			
				DRAWN	CDM	DATE 5/87	
				APPROVED	DGG	DATE 5/87	
				CODE IDENT.			
				2J899	SHEET 1 OF 2		
TITLE FIELD REPLACEABLE SMA JACK, RIGHT ANGLE 4 HOLE FLANGE							DWG. NO. 9958-0781-6720

# SPECIFICATION CONTROL DRAWING

## 3. MECHANICAL

### CAPTIVATION-CENTER CONTACT

MAX AXIAL FORCE \_\_\_\_\_ 6.0 LBS.

MAX RADIAL TORQUE \_\_\_\_\_ 4.0 IN. OZ.

### CENTER CONTACT AXIAL FORCES

● INSERTION (MAX OUNCES) \_\_\_\_\_ INTERFACE 48.0; REAR 32.0

● WITHDRAWAL (MIN. OUNCES) \_\_\_\_\_ INTERFACE 2.0; REAR 1.0

CONNECTOR ENGAGEMENT/DISENGAGEMENT (MAX IN. LBS.)— 2.0

CONNECTOR DURABILITY (MIN. CYCLES) \_\_\_\_\_ 500

RECOMMENDED MATING TORQUE \_\_\_\_\_ 7 - 10 IN. LBS.

## 4. ENVIRONMENTAL

TEMPERATURE CYCLING \_\_\_\_\_ MIL-STD-202, METHOD 102, COND. C ( -65° c TO +200° c )

SHOCK \_\_\_\_\_ MIL-STD-202, METHOD 213, COND. I (100 G's)

VIBRATION \_\_\_\_\_ MIL-STD-202, METHOD 204, COND. D (20 G's)

MOISTURE RESISTANCE \_\_\_\_\_ MIL-STD-202, METHOD 106, LESS STEP 7b

CORROSION \_\_\_\_\_ MIL-STD-202, METHOD 101, COND. B (48 HOURS)

BAROMETRIC PRESSURE (ALTITUDE) \_\_\_\_\_ MIL-STD-202, METHOD 105, COND. C ( 70,000 FT. ) ( 190 VRMS )

## 5. MATERIAL

BODY AND PRESS RING \_\_\_\_\_ STAINLESS STEEL PER AMS-5640, TYPE 303, COND. A

CONTACT \_\_\_\_\_ BERYLLIUM COPPER PER QQ-C-530, ALLOY 173, COND. H.T.

INSULATOR \_\_\_\_\_ TEFLON PER MIL-G-19468 AND L-P-403, TYPE I

EMI GASKET \_\_\_\_\_ SILVER PLATED ALUMINUM IN SILICONE

## 6. FINISH

BODY \_\_\_\_\_ NICKEL PER QQ-N-290, (.00015 MIN. THK.) OR EQUIVALENT

CONTACT \_\_\_\_\_ GOLD per MIL-G-45204, TYPE II, GRADE C, CLASS 2  
(.000100 Minimum Thickness) OVER NICKEL per  
QQ-N-290, CLASS 1 (.000100 Minimum Thickness) OVER  
COPPER per MIL-C-14550 (.000010 Minimum Thickness).

PRESS RING \_\_\_\_\_ PASSIVATE PER QQ-P-35A, TYPE I

INSULATOR \_\_\_\_\_ N/A

EMI GASKET \_\_\_\_\_ N/A